



**GC1K**

**OWNER'S MANUAL**

# WARNING

**FAILURE TO FOLLOW SAFE OPERATING PRACTICES MAY RESULT IN  
SERIOUS INJURY OR DEATH.**

**Read this manual in its entirety before attempting to operate the Intimidator  
Off-Road Vehicle.**

**REMEMBER - YOUR MACHINE IS ONLY AS SAFE AS THE OPERATOR!**

HAZARD CONTROL AND ACCIDENT PREVENTION ARE DEPENDENT UPON THE AWARENESS, CONCERN, PRUDENCE, AND PROPER TRAINING OF THE PERSONNEL INVOLVED IN THE OPERATION, TRANSPORT, MAINTENANCE, AND STORAGE OF THE EQUIPMENT.

This manual provides procedures for minor maintenance, but major repair information can be found in the Intimidator Off-Road Vehicle Service Manual. Major repair should only be performed by an authorized Intimidator Service Dealer.

## Welcome to the Intimidator Family

On behalf of my wife Becky and myself, along with all of us at Intimidator, Inc., we would like to officially welcome you to the family. We are thrilled that you have chosen to become a part of our team. Whether you have purchased your Intimidator for commercial use on your farm, or you just wanted to have the best UTV in your neighborhood, we'd like to say 'Thank You.'

We are fiercely loyal to our customers and work hard to provide the highest quality of products, parts and accessories at the best possible price. We strive to create a unique experience for our customer that will differentiate Intimidator Off-Road Vehicles from the rest of the industry. Our Vision is to build the best off-road utility vehicle on the market. We will continue to work with experts in our field to provide a superior machine that is second to none in power, durability and performance.

We look forward to our future together and hope to be partners for as long as there are trails to ride.

Thank you and again, welcome to the family!

Handwritten signatures of Robert and Becky in black ink.

Robert & Becky  
Foster Intimidator,  
Inc. Owners



# Table of Contents

---

<b>Introduction .....</b>	<b>5</b>
<b>Definitions .....</b>	<b>5</b>
<b>Safety .....</b>	<b>6</b>
<b>Features, Controls, and Operation.....</b>	<b>15</b>
<b>New Vehicle Break-In .....</b>	<b>29</b>
<b>Maintenance .....</b>	<b>30</b>
<b>Troubleshooting .....</b>	<b>54</b>
<b>Storage .....</b>	<b>57</b>
<b>Transporting Your Intimidator.....</b>	<b>58</b>
<b>Accessories .....</b>	<b>58</b>
<b>Specifications .....</b>	<b>59</b>
<b>Warranties.....</b>	<b>68</b>
<b>Service Records .....</b>	<b>72</b>
<b>Intimidator Inc. Utility Vehicle Owner’s Registration and Training Certification .....</b>	<b>72</b>
<b>Pre-Ride Checklist .....</b>	<b>73</b>

# Introduction

---

## Read this owner's manual.

The Intimidator is an off-road vehicle, not a toy. It can be hazardous to operate and should never be operated by anyone other than a trained adult. Failure to follow the warnings and instructions in this manual can result in severe injury or death.

## Product Identification Number (PIN)

Your machine's PIN is located between the seat back and cargo bed.



Figure 1: PIN Label

# Definitions

---

### **Danger:**

Indicates a hazardous situation that, if not avoided, may result in serious injury or death

### **Warning:**

Indicates a situation that, if not avoided, may result in property damage

### **Notice:**

Indicates a situation that could result in property damage

# Safety

For your protection, warning labels are placed on the vehicle. Read and follow the instructions on the vehicle carefully. If any label becomes illegible or comes off contact your authorized dealer to acquire a replacement.

## Discretionary and Age Warning – Located on vehicle dash



Figure 2: Discretionary Warning Label

### Danger:

- Improper Use of Off-Highway Vehicles Can Cause Severe Injury or Death

### Drive Responsibly

Avoid loss of control and rollovers:

- Avoid abrupt maneuvers, sideways sliding, skidding, or fishtailing, and never do donuts.
- Slow down before entering a turn.
- Avoid hard acceleration when turning, even from a stop. Plan for hills, rough terrain, ruts, and other changes in traction and terrain.
- Avoid paved surfaces.
- Avoid side hilling (riding across slopes).

### Require Proper Use of Your Vehicle

An UTV operator safety course, either through your dealer or online at [www.rohva.org](http://www.rohva.org) is highly recommended.

### Do your part to prevent injuries:

- Do not allow careless or reckless driving.
- Make sure operators are 16 or older with a valid driver's license.
- Do not let people drive or ride while under the influence of alcohol or drugs.
- Do not allow operation on public roads (unless designated for off-highway vehicle access) – collisions with cars and trucks can occur.
- Do not exceed seating load capacity.

## Seatbelt and Safety Warning – Located on vehicle firewall

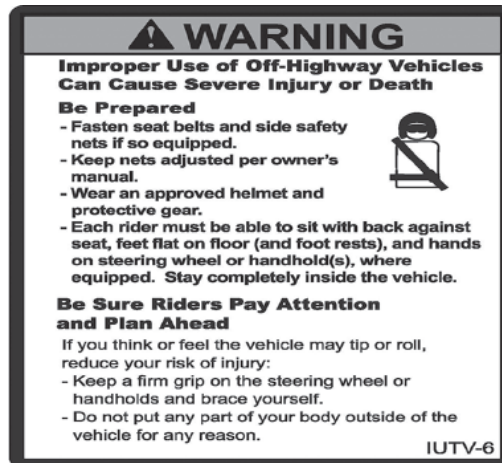

Figure 3: Seatbelt and Safety Label

### Warning:

- Improper Use of Off-Highway Vehicles Can Cause Severe Injury or Death.

### Be Prepared:

- Fasten seat belts and side safety nets if so equipped.
- Keep nets adjusted per owner's manual.
- Wear an approved helmet and protective gear.
- Each rider must be able to sit with back against seat, feet flat on floor (and foot rests), and have hands on steering wheel or handhold(s), where equipped. Stay completely inside the vehicle.

### Be Sure Riders Pay Attention and Plan Ahead

If you think or feel the vehicle may tip or roll, reduce your risk of injury:

- Keep a firm grip on the steering wheel or handholds and brace yourself.
- Do not put any part of your body outside of the vehicle for any reason.

## ROHVA and ISO Certification Sticker – Located on the driver's side below the roll cage.



Figure 4: ROHVA Label 1

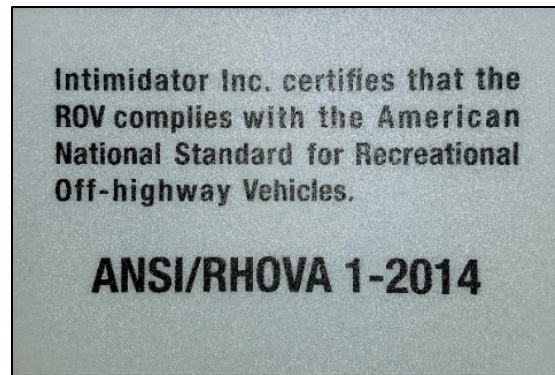

Figure 5: ROHVA Label 2

**Cargo Bed Safety Warning** – Located in the cargo bed.

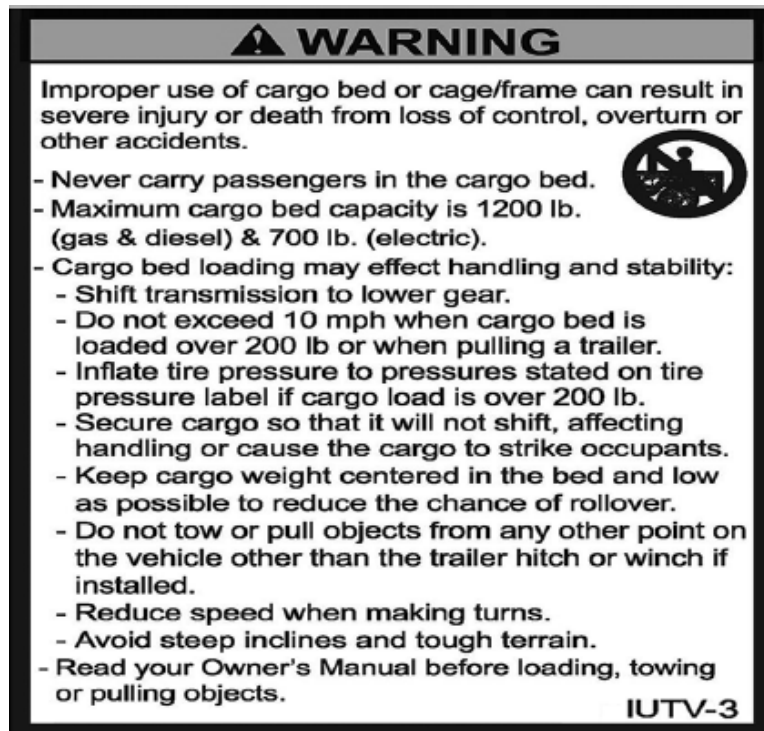

Figure 6: Cargo Bed Safety Label

**Warning:**

- Improper use of cargo bed or cage/frame can result in severe injury or death from loss of control, overturn or other accidents.
- Never carry passengers in the cargo bed.
- Maximum cargo bed capacity is 1200 lb. (gas & diesel), 700 lb. (electric), and 1000 lb. (GC1K).
- Cargo bed loading may affect handling and stability:
  - Shift transmission to lower gear.
  - Do not exceed 10 mph when cargo bed is loaded over 200 lb. or when pulling a trailer.
  - Inflate tire pressure to pressures stated on tire pressure label if cargo load is over 200 lb.

- Secure cargo so that it will not shift, affecting handling or cause the cargo to strike occupants.
- Keep cargo weight centered in the bed and as low as possible to reduce the chance of rollover.
- Do not tow or pull objects from any other point on the vehicle other than the trailer hitch or winch if installed.
- Reduce speed when making turns.
- Avoid steep inclines and tough terrain.
- Read your owner's manual before loading, towing, or pulling objects.

**Tilt Cargo Bed Warning** – Located near the handle on the driver's side of the cargo bed.

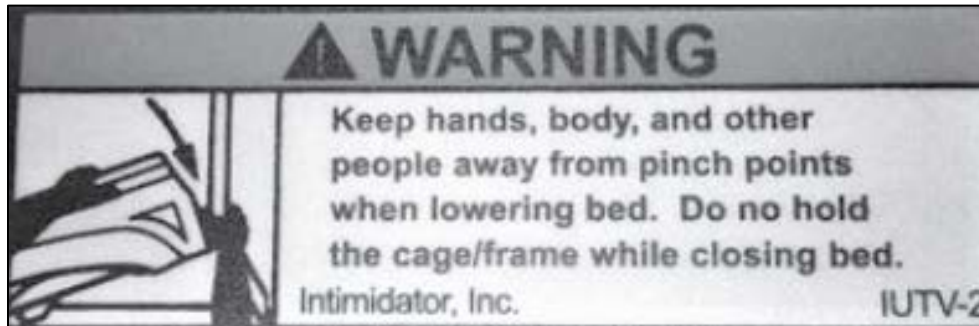

**Figure 7: Tilt Cargo Bed Label**

**Warning:**

- Keep hands, body, and other people away from pinch points when lowering bed.
- Do not hold the cage/frame while closing bed.

**Tire Pressure Chart** – Located inside of the cargo bed on the driver's side.

INTIMIDATOR CLASSIC SERIES	1900C EFI GAS	1800C DIESEL	ELECTRIC
TIRE PRESSURE IN PSI (NO LOADS)	FRONT 12 REAR 12	FRONT 12 REAR 12	FRONT 12 REAR 12
TIRE PRESSURE IN PSI (CARGO)	FRONT 18 REAR 22	FRONT 18 REAR 22	FRONT 18 REAR 22
MAXIMUM CARGO BED LOAD	1,200 lbs	1,200 lbs	700 lbs
CURB WEIGHT	1,211 lbs	1,494 lbs	2,255 lbs
GVWR	2,200 lbs	2,200 lbs	2,500 lbs
MAXIMUM PAYLOAD (INCLUDES WEIGHT OF OPERATOR, PASSENGER, CARGO AND ACCESSORIES)	1,000 lbs	1,000 lbs	1,300 lbs
MAXIMUM TOWING CAPACITY	2,100 lbs	2,100 lbs	1,500 lbs

Read Owner's Manual for more detailed loading information.

Intimidator, Inc. 791-2034-00

**Figure 8: Tire Pressure Label**

## Tire Rating and Pressure Chart

<b>Tire Position</b>	<b>Size</b>	<b>Max Load Rating (lb.) at Max Pressure</b>	<b>Max Pressure (PSI)</b>
Front	27x10R14	750	18
Rear	27x12R14	1275	22
Front	28x10.5R14	1000	26
Rear	28x10.5R14	1000	26
Front	30x10.5R15	1000	26
Rear	30x10.5R15	1000	26

## Roll Over Protective Structure (ROPS) Inspection Guide

ROPS, like any other safety device, need to be periodically inspected to verify that the integrity of the device has not been compromised through normal machine use, misuse, age degradation, modifications, or roll-overs.

Some mechanical discretion is essential, therefore personnel who inspect ROPS need to comprehend and understand the significance of issues like structural corrosion, cracks, and deformation. If in doubt, remove the machine from service and contact the ROPS manufacturer for assistance. Certain conditions will absolutely render the ROPS unusable. Examples are:

- Permanent deformation or twisting.
- Missing, damaged, or loose mounting hardware.
- Mounting hardware that is of a grade lesser than specified.
- Any cracks in the structure (structural members and/or welds).
- Significant corrosion.
- Modifications such as unauthorized welds and holes.
- Missing or unreadable ROPS label.
- Applicable ROPS machine model not specified on the ROPS label.
- Missing seatbelts.
- Incomplete/improper installation.

Other conditions may require immediate service but may not render the unit unusable. Examples are:

- Faded paint.
- Faded, hard to read ROPS label.
- Slightly corroded mounting hardware.

ROPS must be inspected immediately after any type of collision, rollover, or impact. If any damage is evident, the ROPS must be removed from service and replaced.

When a ROPS is removed or installed, mounting hardware must be examined for signs of over-stressing. Damaged mounting hardware must be replaced with proper specification hardware before placing the ROPS back into service.

Properly maintained seatbelts are essential to compliment the operator crush protection designed into the ROPS. All seatbelt and/or seatbelt anchorage systems that show evidence of cuts, fraying or wear, significant discolorations due to exposure to the elements, heavy soiling (especially with oil, grease, or fuel), or any type of damage must be immediately replaced, regardless of age.

## General Safety

### Never Operate

- If you are under age 16 or without a valid driver's license.
- At speeds too fast for your skills or conditions.
- While under the influence of alcohol or drugs.
- On hills steeper than 15 degrees.
- On public roads or paved surfaces.
- With more than two passengers (five for crew models).
- With any passenger who cannot reach the grab handles.
- With passengers in the cargo box.
- With non-approved accessories or modifications.

### Always

- Wear your seatbelt. Vehicle rollover could cause serious injury or death.
- Make sure that both doors are latched before operating the vehicle.
- Wear a helmet and eye protection.
- Reduce speed and use extra caution while carrying passengers.
- Avoid sharp turns or turns while applying heavy throttle.
- Operate slowly in reverse. Avoid sharp turns or sudden braking.
- Make sure passengers read and understand all safety labels.

### Operator Safety

- Operator and passengers must fasten seatbelts and ensure that both safety nets or doors are secure while the vehicle is in use. If doors/safety nets are damaged or show significant wear, do not use the vehicle until new components are installed.
- Never operate your vehicle in fast-flowing water or in water deeper than the floorboard. Wet brakes may have reduced stopping ability. Test your

brakes after leaving water. If necessary, apply brakes lightly several times to let friction dry out the pads.

- Check terrain before attempting to climb a hill. Never climb hills with excessively slippery or loose surfaces. Never open the throttle suddenly or make sudden gear changes. Never go over the top of a hill at high speeds.
- Always use the proper size and type of tires specified in this manual. Always maintain proper tire pressure as specified on safety labels.
- Never modify this vehicle through improper installation or use of accessories.
- Never exceed the stated load capacity for this vehicle. Cargo should be properly distributed and securely attached. Reduce speed and follow the instructions in this manual for hauling cargo or pulling a trailer. Allow greater distance for braking.
- Always put the shift lever into Park before getting out of the vehicle.
- Always stop the engine before refueling. Remove flammable material containers from the cargo box before filling them with fuel. Make sure the refueling area is well ventilated and free of any source of flames or sparks.
- Always remove the ignition key when the vehicle is not in use to prevent unauthorized use or accidental starting.
- Exhaust system components are very hot during and after use of the vehicle. Hot components can cause burns and fire. Do not touch hot exhaust system components. Always keep combustible materials away from the exhaust system. Use caution when traveling through tall grass, especially dry grass. Never start the engine or let it run in an enclosed area.
- Do not carry a passenger until you have at least two hours of driving experience with the Intimidator.
- Always keep hands and feet inside the vehicle at all times.
- Always inspect the vehicle before each use to make sure it is in safe operating condition. Follow inspection procedures described in this manual.

### **Operating a Damaged Vehicle**

Operating a damaged vehicle can result in an accident. In the case of an overturn or other accident, have a qualified service dealer inspect the entire machine for possible damage, including (but not limited to) brakes, throttle, and steering systems.

### **Operating at Excessive Speeds**

Operating this vehicle at excessive speeds increases the operator's risk of losing control.

## **Operating on Pavement**

This vehicle's tires are designed for off-road use only, not for use on pavement. Operating this vehicle on paved surfaces may cause excessive tire wear and may adversely affect the handling of the vehicle and could result in loss of control, accident, or overturn. If it is unavoidable, travel slowly and avoid sudden turns or stops.

## **Turning Improperly**

Turning improperly could cause loss of traction, loss of control, accident, or overturn. Always follow turning procedures for turning. Never turn abruptly or at sharp angles. Never turn at high speeds. Never abruptly accelerate while turning.

## **Jumps and Stunts**

Attempting wheelies, jumps, and other stunts increases the risk of accident or overturn. Never attempt wheelies, jumps, or other stunts. Avoid exhibition driving.

## **Improper Hill Climbing**

Climbing hills improperly can cause loss of control or vehicle overturn. Do not climb a hill or drive down a hill with a slope of more than 15 degrees.

## **Stalling While Climbing a Hill**

Stalling or rolling backwards while climbing a hill could cause an overturn. Always maintain a steady speed when climbing a hill.

If all forward speed is lost:

- Apply the brakes. Place the transmission in reverse and slowly allow the vehicle to roll straight downhill while applying light brake pressure to control speed.

If you begin rolling downhill backwards:

- Never apply engine power
- Apply the brakes gradually until the vehicle is fully stopped.
- Place the transmission in reverse and slowly allow the vehicle to roll straight downhill while applying light brake pressure to control speed.

## **Improper Tire Size, Type, or Maintenance**

Operating this vehicle with improper tire size or type may void the warranty. See your dealer for details. Operating this vehicle with uneven or low tire pressure could cause loss of control or accident. Always use the size and type of tires specified for your vehicle. Always maintain proper tire pressure as described in the owner's manual and on the safety labels.

## **Equipment Modifications**

We strongly recommend that consumers do not install any after-market equipment that may increase the speed or power of the vehicle, or make any other modifications to the vehicle for these purposes. Any modifications to the original equipment of the vehicle create a substantial safety hazard and increase the risk of bodily injury.

The warranty of the Intimidator will void if any unauthorized equipment is added to the vehicle, or if any modifications are made to the vehicle that increase the speed or power.

The addition of certain accessories, including (but not limited to) mowers, blades, large tires, sprayers, or large racks may change the handling characteristics of the vehicle. Use only factory approved accessories, and familiarize yourself with their function and effect on the vehicle.

## **Safe Riding Gear**

Always wear appropriate clothing when riding the Intimidator. Wear protective clothing for comfort and to reduce the chance of injury.

### **Helmet**

Wearing a helmet can prevent a severe head injury. Whenever riding the Intimidator or any utility vehicle, always wear a helmet that meets or exceeds established U.S. Department of Transportation (DOT) safety standards.

### **Eye Protection**

Do not depend on eyeglasses or sunglasses for eye protection. Always wear shatterproof goggles or use a helmet with a shatterproof face shield.

### **Gloves**

Wear gloves for comfort and protection from sun, cold weather, and other elements.

### **Boots**

Wear sturdy footwear. Do not drive or ride with bare feet.

### **Clothing**

Wear long sleeves and long pants to protect arms and legs.

# Features, Controls, and Operation

---

## Ignition

Your key is a series type key, of which there are a high range of numbers. It is highly recommended that you obtain additional copies of your key. If all keys are lost, a replacement ignition switch must be installed.

## Starting the Intimidator

To start the engine, press the brake pedal and turn the ignition key to the “ON” position. The machine can start in any gear, but it is recommended that the transmission is placed in “Park” before attempting to start the engine. For the best throttle response and performance, allow the engine to idle for at least one minute after each cold start before applying throttle.

## Display

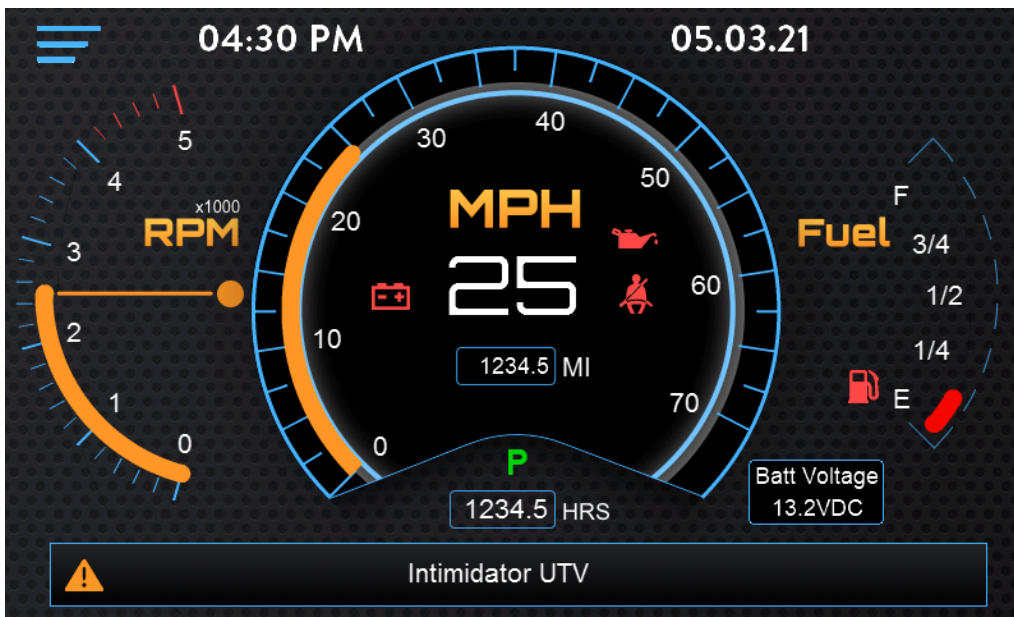

**Figure 9: 7" Display**

The 7" LCD display and surrounding buttons and switches contain the controls necessary to operate the UTV. The display will allow access to the machine, notify the user of maintenance needs, and help to show relevant information during operation.

### **Danger:**

- Do not attempt to operate the display while the vehicle is in motion

### **Notice:**

- Do not expose the display to excessive moisture or attempt to clean it with a pressure washer

### **Fault Screen**

This screen is accessible by touching the message box only when a fault is active. This screen will list active faults.

### **Menu Screen**

Menu screen allows the user to change LCD brightness, units of measurement, and date and time.

## Switches



Figure 10: GC1K Switches

From left to right:

1. Light Switch
2. 2 Wheel Drive/ 4 Wheel Drive Switch
3. Rear Differential Lock Switch
4. Electric Bed Dump Switch

## Lights

All models come equipped with automotive style headlights. Press the switch down to turn on the low beam lights. Press the switch up to turn on the high beam lights. To turn the lights off, place the switch into the middle position.

## Dash Lights

All of the warnings and lights can be found either on the main screen of the display gauge or under the diagnostics screen. Under diagnostics you will find all of the error codes that you've received.

## Engaging and Disengaging 4 Wheel Drive (4WD)

### Warning:

- Do not drive in 4wd on a paved surface.
- Do not engage 4wd while the rear wheels are spinning without traction. Always engage 4wd while the rear wheels have traction or are at rest.
- Engage 4wd before entering conditions where it may be needed. If the rear wheels are spinning, release the throttle before switching to 4wd.

To engage 4wd, press the 4wd dash switch so that the switch light is illuminated. You may engage 4wd while the vehicle is moving while taking the precautions mentioned above.

To disengage 4wd, press the 4wd dash switch so that the switch light is off. In some situations, the front differential may remain locked after turning the 4wd switch off. If this occurs, you may continue to notice increased steering effort and some vehicle speed restrictions. Perform the following procedure to unlock the front differential:

1. Stop the vehicle
2. Operate in reverse for at least 10 feet.
3. Shift into a forward gear and drive.

## Locking Rear Differential

### **Danger:**

- Steering and vehicle performance will be altered with the rear differential lock engaged.
- Do not operate faster than 10 mph while on a paved surface. Off-road utility vehicles are not intended to operate on paved surfaces.

To engage the differential lock, press the emblem side of the switch. The switch light will turn on, meaning the differential lock is engaged. If one of the rear wheels should slip, press the switch to turn on the differential lock. Both wheels will then turn together, increasing traction. When the ignition is turned off, the rear differential lock is automatically engaged.

## Electric Dump Bed (if equipped)

Press and hold the upper end of the rocker switch to dump the cargo bed. Quickly release the switch when the tilt height has maxed out or the actuator starts to make a clicking sound. To lower the bed, press and hold the lower end of the rocker switch. Quickly release the switch when the bed is down or the actuator starts to make a clicking sound.

### **Truck Double Actuator**

Make sure to fully bottom out the truck electric dump bed each time it is raised. The actuators will move at slightly different rates and fully bottoming out the bed will ensure that there is no twisting of the bed which may cause damage.

## Electrical

### Double USB Port



**Figure 11: Ignition and Double USB Port**

The double USB Port is located on the driver's side next to the ignition switch. The USB ports are both DC5V. The top port is 2.4A and the bottom is 1.0A. They can both be used as chargers for any USB compatible device and will allow USB connectivity with the 7" gauge.

- These outlets are activated when the key is switched to the "ON" position.
- Do not connect any device that draws more than 120 watts to this connector or the battery may discharge rapidly or the outlet may fail.
- Do not use when wet
- Unplug all accessories when the vehicle key is switched to the "OFF" position.

### 12V Accessory Port

#### Warning:

- Do not use the 12V accessory port to heat a cigarette lighter

Some models are equipped with a 12V accessory port.

- The port is activated when the key is switched to the "ON" position.
- Do not connect any device that draws more than 120 watts to this connector or the battery may discharge rapidly or the outlet may fail.
- Do not use when wet
- Unplug all accessories when the vehicle key is switched to the "OFF" position.

### Adding Switches and In-Dash Accessories

The Intimidator is designed to allow the dealer to add more switches for accessories and "built-in" accessories like a light bar or sound system. There are two open slots in the switch panel of stock GC1K machines to allow for additional accessories. To minimize the risk of damage to the machine, contact your authorized dealer.

## Parking Brake

### Warning:

- Do not attempt to place the transmission into “Park” while the vehicle is in motion. Always stop the unit completely before attempting to shift.
- The vehicle’s gear shift lever comes properly adjusted from the factory so that the park gear is fully engaged and will not slip. During every pre-ride inspection, check that the gear shift lever is fully engaged into “Park” and will not slip out of gear. Have your authorized dealer annually inspect, lubricate, adjust, or replace the shifter cable.
- When your vehicle is not in use or the key is switched to the “off” position, always place the transmission in “Park.”
- Always tie down your vehicle with chains or straps when transporting it on a truck or trailer. Never rely on the parking brake alone. See “Transporting Your Intimidator.”

Your Intimidator is equipped with a “Park” gear. While your vehicle is in “Park” with the engine off, both rear wheels will lock. Your vehicle’s transmission should be set in “Park” at all times when not in use. If you have hauling or towing heavy loads, always park on level ground. To engage the parking brake, stop the vehicle completely and use the shift lever to move the transmission to the “Park” gear.

## Stand-Alone Parking Brake

### Warning:

- Improper operation of the parking brake system can result in damage to the brakes and drive system.
- Do not attempt to engage stand-alone parking brake while the vehicle is in motion.
- Allow 5 seconds after disengaging stand-alone parking brake for the system to fully disengage prior to moving the vehicle.

Intimidator crew and truck models can be equipped with a stand-alone parking brake system that locks the rear wheels.

To engage the parking brake:

1. Safely bring the vehicle to a complete stop on a flat, level surface and shift the transmission into “Park.”
2. Press the toggle switch on the dash to engage the parking brake. A small LED light will illuminate to indicate that the system is engaged.
3. Shut down the engine before removing the seat belt and exiting the vehicle.

To disengage the parking brake:

1. Ensure that all occupants are safely secured.
2. Fully depress the brake pedal, and start the engine.
3. Press the toggle switch on the dash to disengage the parking brake and wait 5 seconds. The LED light will turn off it indicate that the system is disengaged.
4. Operate the vehicle normally.

## Shifting Gears

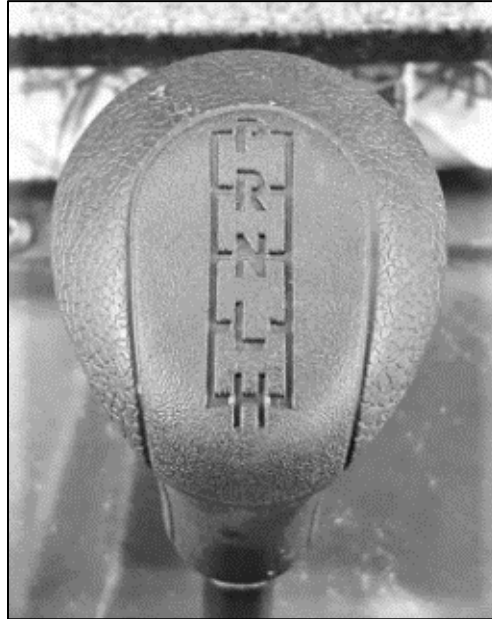

**Figure 12: Gear Shift Lever**

### **Warning:**

- Do not attempt to shift gears while the vehicle is in motion.
- Always come to a complete stop and hold the brake before attempting to shift into a new gear.

The Intimidator is equipped with a gear selection icon shown on the instrument cluster's digital display. To shift, bring the vehicle to a complete stop, depress the brake, and move the shift lever to the desired gear. Confirm the gear selection on the LCD screen.

## Rollover Protective Structure (ROPS)

### **Danger:**

- Vehicle rollover could cause serious injury or death. Always avoid operating in a manner that could result in vehicle rollover
- Do not grab or hold ROPS while vehicle is moving. If a rollover occurs, holding the ROPS could cause serious injury.
- Modifying or cutting the ROPS can cause serious injury or death.
- Do not add any unauthorized accessory that bolts into the ROPS mounting points.

The ROPS on this vehicle meets American National Standards Institute (ANSI) standards and OSHA standards for rollover performance requirements. Always have an authorized Intimidator dealer thoroughly inspect the ROPS if it ever becomes damaged in any way.

## Seatbelts and Half Doors



**Figure 13: GC1K Doors**

### **Danger:**

- Always fasten your seatbelt and secure the doors to prevent unwanted egress from a moving vehicle
- Riding in this vehicle without using the factory installed doors increases the risk of serious injury or death.
- Inspect the doors for wear and damage prior to each use.
- If the driver seat belt is not fastened, the engine limiter will engage, preventing speeds of more than 15 mph.
- Prolonged operation of the engine with the limiter engaged can result in engine damage

## Seat Removal

Pull up on the front of the seat and slide it towards the front of the vehicle. To install the seat, slide the seat into the rear of the seat base until the two metal studs attached to the front of the seat are aligned with the two rubber grommets attached to the front of the seat base. Push down firmly on the front of the seat until the studs are fully seated into the grommets.

## Tilt Steering



**Figure 14: Steering Column**

Your Intimidator is equipped with tilt steering that can be adjusted by pulling the tilt steering lever towards you, then lifting the steering wheel up or pressing it down. The tilt steering lever is located on the steering column, directly behind the steering wheel.

## Hauling Cargo

### **Danger:**

Always follow these precautions when hauling cargo:

- Refer to the cargo bed safety warning label, located in the cargo bed.
- Driving with passengers in the cargo box can result in severe injury or death. Never allow passengers to ride in the cargo box. Passengers must always ride in the cab with seatbelts fastened securely.
- Hauling cargo improperly can alter vehicle handling and may cause a loss of control which can result in serious injury or death.
- Never exceed the maximum weight capacity of the vehicle. When determining the weight that you are adding to the vehicle, include the weight of the operator, passengers, accessories, cargo loads, and the load on the trailer tongue. The combined weight of these items must not exceed the maximum weight capacity.

- Reduce speed and allow greater distances for braking when hauling cargo.
- Always load the cargo box with the load as far forward and as low as possible.
- When operating over rough or hilly terrain, reduce speed and cargo to maintain stable driving conditions.
- Always operate the vehicle with extreme care when hauling or towing loads.
- Slow down and drive in low range if possible.
- Secure all loads before operating.
- Vehicle should never exceed 10 mph while towing a heavy load on a level grass surface. Vehicle speed should never exceed 5 mph when towing heavy loads in rough terrain, while cornering, or while ascending or descending a hill.
- Use extreme caution when applying brakes with a loaded vehicle. Avoid terrain or situations that may require braking downhill. Allow extra distance for braking.

## Cargo Bed

### **Danger:**

- Do not sit or stand on the tailgate.
- Do not place fingers or hands between the tailgate and the latch when closing

To open the tailgate, twist the latch in the middle of the tailgate and then pull. The tailgate is supported by tailgate cables. Do not remove the cables.

### **Dumping the Cargo Box**

### **Danger:**

- Do not attempt to dump the cargo box while on an incline.
- If the weight in the cargo box is located towards the rear of the box when the release lever is lifted, the box may dump unexpectedly and cause serious injury.
- Distribute the load evenly throughout the cargo box.

### **Warning:**

- If the cargo box is loaded to full weight capacity it may be difficult to dump.
- Use extreme caution.

To use the cargo dump box:

1. Select a level site to dump the cargo box. Do not attempt to dump or unload the vehicle while parked on an incline.
2. Safely place the transmission into "Park." (Engage the stand-alone parking brake if equipped.)
3. Dismount the vehicle.
4. Ensure that the cargo is positioned evenly in the cargo box.
5. Lower the tailgate.
6. Position yourself next to the cargo box release lever located on the driver's side of the cargo box.



**Figure 15: Bed Release Latch**

7. Pull up on the cargo box release lever, and lift the front of the box to dump the cargo.
8. Lower the cargo box and push down securely to engage the latch.



**Figure 16: Standard Dump Box Lift Assist**

## Electric Dump Bed



**Figure 17: Single Electric Dump Bed Actuator**

Press and hold the rocker switch on the side with the arrow pointing up to dump the cargo bed. Quickly release the switch when the actuator starts to make a clicking sound. To lower the bed, press and hold the rocker switch on the side with the arrow pointing down. Quickly release the switch when the actuator starts to make a clicking sound.

## Towing

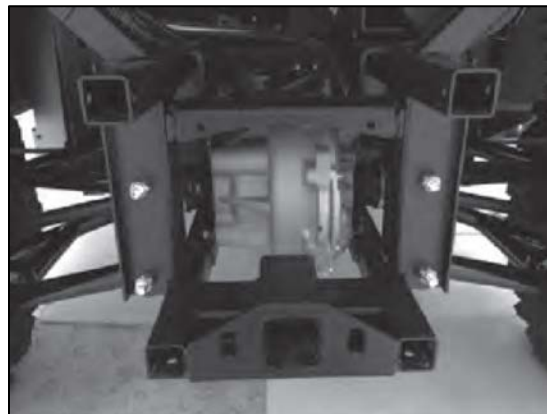

**Figure 18: 2" Receiver Hitch**

### **Danger:**

Always follow these precautions when towing a load.

- Never load more than 300 lb. tongue weight on the rear towing bracket.
- Never load more than 200 lb. tongue weight on the front towing bracket.
- Do not operate the vehicle faster than 10 mph when hauling or towing loads on a level surface.
- Do not exceed 5 mph when hauling or towing loads on uneven surfaces, rough terrain, while cornering, or while ascending or descending a hill.
- Do not tow more than the recommended weight for the vehicle.

- Attach a trailer to the rear trailer hitch bracket only. Do not attach a trailer to any other location or you may lose control of the vehicle.
- Never tow a trailer on a grade steeper than 15 degrees.
- Always operate in low gear when hauling or towing in excess of 200 lb. with either the cargo bed or trailer.

## Adjusting Rear Shock Position



**Figure 19: Rear Shock Assembly**

### **Danger:**

When adjusting the rear shock position:

- Work on a firm, flat, level surface with the engine off.
- Place the transmission in “Park.”
- Keep the position of the left and right shock absorbers equal. Uneven adjustments can cause loss of control.

### **Notice:**

- A special tool is required to adjust the shock spring.
- Authorized Intimidator dealers are equipped to make these adjustments for you.

All four shock absorbers have adjustable features that increase or decrease their stiffness. We recommend that these adjustments be made by an authorized Intimidator dealer to suit the conditions that the machine will encounter.

In addition to the four spring position adjustments, the rear shock absorbers have multiple mounting positions to further adjust the stiffness of the ride by changing the angle in which the shocks are mounted. With heavy loads, the shocks should

be mounted in the near-vertical position. For light-to-medium size loads and a smoother ride, the shocks can be mounted at a steeper angle which will also increase wheel travel.

## Fuel

### **Danger:**

- Handle fuel carefully
- Do not fill the fuel tank with the engine running.
- Do not smoke while filling the fuel tank or servicing the fuel system.
- Fill the fuel tank to the bottom of the filler neck.
- Do not use E15, E20, or E85 fuels.

### **Notice:**

- It is recommended to only use unleaded gasoline with an index rating of 90 or higher.
- The effects of old, stale, or contaminated fuel are not covered by warranty.
- Use fuel within 30 days of purchase to avoid deterioration in gasoline quality, or add fuel stabilizer to keep fuel fresh.
- Use gasoline within the season it was purchased
- Never remove the fuel tank cap or add fuel with the engine running.
- Allow to the engine to cool before refueling.
- Never overfill the fuel tank. Tighten the cap securely when the tank has been properly filled.
- Clean up spilled fuel immediately. If fuel is spilled near the vehicle, do not attempt to start the engine. Move the vehicle away from the spill.

# New Vehicle Break-In

---

The first 20 hours of riding are the most important hours in the life of your engine. Read the and follow these instructions to properly break-in your new Intimidator.

Do not put an excessive load on the engine for the first 20 hours. During this time the various parts of the engine wear and polish themselves to optimal operating tolerances. Full-throttle operation or any condition that might result in engine overheating must be avoided.

## **0-10 Hours:**

- Avoid prolonged operation above  $\frac{1}{2}$  throttle.
- Vary the speed of the UTV regularly.
- Do not operate at one set throttle position.

## **10-20 Hours:**

- Avoid prolonged operation above  $\frac{3}{4}$  throttle.
- Rev the engine freely, but do not use full throttle at any time

## **20+ Hours:**

- The engine can now be operated normally

Once the engine reaches 20 hours of run-time it needs to be serviced.

The first service is essential for checking for any indications of potential future issues. We recommend that an authorized Intimidator dealer perform the initial service to ensure a long and reliable service life for your machine.

# Maintenance

---

Careful periodic maintenance will keep your vehicle in the safest, most reliable condition. Inspection, adjustment, and lubrication of important components are explained in this section.

Inspect, clean, lubricate, adjust, and replace parts as recommended by the periodic maintenance chart in this manual. When inspection reveals the need for replacement parts, use genuine Intimidator parts, available from your authorized Intimidator dealer.

Maintenance intervals in the periodic maintenance chart are based upon average riding condition. Vehicles subject to severe use must be inspected and serviced more frequently.

## Severe Use Definition

- Extended idle.
- Short-trip, cold weather operation.
- Prolonged low-speed, heavy-load operation.
- Frequent or prolonged operation in dusty environments.
- Frequent immersion in mud, water, or sand.
- Prolonged high speed and high RPM use.

If your vehicle falls under the severe use definition, perform all maintenance at intervals more frequent than stated on the chart.

## Intimidator GC1K Engine Specifications

Bore	3.62 in (92 mm)
Stroke	2.95 in (75 mm)
Displacement	45.6 in <sup>3</sup> (997cc)
Oil Capacity (refill)*	2 quarts (1.9 L)
Oil Type	Intimidator SYN 10W-40**
Spark Plug Gap	0.3 in (0.75 mm)
Max Angle of Operation	30 degrees
*Filter capacity not included. Always check the dipstick before operation	
**Factory filled with this recommended fluid	

## Intimidator Lubrication and Fluid Chart

### Recommended factory fluids

Item	Lubricant	Quantity
Brake Fluid	DOT 3	Between min and max
Front Differential Oil	Shell Spirax S3 TLV	180 ml
Rear Differential Oil	Shell Spirax S4 AX 80w90	550 ml
Transmission/Gearbox Oil	Valvoline SYN 75W-140	750 ml

### Periodic Maintenance Schedule

#### Notice:

- Clean or replace the air cleaner element more often when the engine is operated on dusty roads or in a heavily polluted environment.
- Maintenance should be performed more often if the engine is frequently operated at high speed and after the engine has accumulated a higher mileage.
- Preventative Maintenance:
  - Ignition System – perform maintenance and check when continuous abnormal ignition, misfire, after-burn, or overheating occur.
  - Carbon Deposit Removal – remove carbon deposits in cylinder head, piston heads, and exhaust system when power is obviously lower than normal
  - CVT belt – replace if there are cracks or abnormalities on the surface

Item	Interval (whichever comes first)	Remarks
Clean engine surroundings/components of debris	Pre-ride	
Cab Safety Nets/Doors	Pre-ride	Check for tightness, damage, and operation
Seat Belts	Pre-ride	Check for damage and operation
Shift Linkage	Pre-ride	Make sure “Park” will fully engage. Adjust if necessary
Coolant Hoses	Pre-ride	Inspect, adjust
Coolant Level	Pre-ride	Inspect, adjust
Brake Fluid Level	Pre-ride	Inspect, adjust
Brake System/ Throttle Pedal Travel	Pre-ride	Inspect, adjust

Fuel, Oil Level	Pre-ride	Inspect, adjust
Steering	Pre-ride	Inspect, adjust
Front Suspension	Pre-ride	Inspect, adjust
Rear Suspension	Pre-ride	Inspect, adjust
Tires	Pre-ride	Inspect, adjust
Wheels/Fasteners	Pre-ride	Inspect, adjust
Frame	Pre-ride	Inspect
Headlights, Tail Lights	Pre-ride	Inspect, adjust
Axle, Steering Joint Boots	Pre-ride	Inspect, adjust
Air Filter	10hr /monthly	Clean, replace if necessary
Change Engine Oil (initial break-in only)	20hr	Change engine oil, filter
Check Valve Clearance	25hr /3 months	Check, adjust if necessary
Brake Pads	25hr /3 months	Inspect
Service Air Filter	25hr /3 months	Inspect, clean, replace if necessary
Battery	25hr /3 months	Check terminals
Transmission/Gearbox Oil	25hr /3 months	Inspect level, change yearly
Rear Differential Oil	25hr /3 months	Inspect, change yearly
Front Differential Oil	25hr /3 months	Inspect, change yearly
Change Engine Oil and Filter (reoccurring)	50hr /6 months	
Spark Arrestor	At every oil change	Inspect, clean, replace if necessary
Engine Oil Cooler Fins	100hr /12 months	Clean as necessary
Driveshaft U-joints and Spline Shafts	100hr /12 months	Lubricate zerk fittings
Shift Linkage	100hr /12 months	Inspect, lubricate, adjust
Steering	150hr /12 months	Inspect, lubricate
Throttle Cable	150hr /12 months	Inspect, adjust, lubricate, replace if necessary

CVT Belt	150hr /12 months	Inspect, replace if necessary
Valve Clearance	150hr /12 months	Inspect, adjust
Fuel System	250hr /24 months	Inspect for leaks, change fuel filter
Coolant	250hr /24 months	Drain, replace
Engine Mounts	250hr /24 months	Inspect
Wiring	250hr /24 months	Inspect for wear, apply dielectric grease to connectors
Spark Plugs	250hr /24 months	Replace if needed
Ignition Timing	250hr /24 months	Adjust
Exhaust System	250hr /24 months	Inspect for leaks, operation
Brake Fluid	350hr /36 months	Drain, change fluid
CVT Clutch	350hr /36 months	Inspect, clean, replace worn parts
Wheel Bearings	350hr /36 months	Inspect, adjust
Toe Adjustment	350hr /36 months	Inspect, adjust

## Fuse and Relay

Fuses and relays can be found in a fuse box under the front hood. The main fuse, located near the main battery, is a 60A fuse.

### Fuse Block

#### Fuse Chart

Main Fuse (Battery)	60A
Differential Lock	10A
Headlight Low Beam	10A
Headlight High Beam	10A
Power Port	20A
Electric Bed Dump Actuator (if equipped)	20A

## Fault Codes

If your vehicle is having an issue and you are able to obtain data from a fault code reader it may help to resolve the issue more quickly.

Number	Fault Code	Description
1	XXXXX	Un defined
2	B2225	Tilt switch diagnosis (Short Circuit Battery)
3	B2226	Tilt switch diagnosis (Short Circuit Ground/Open Circuit)
4	P0000	No DTC
5	P0031	Sensor heater diagnosis #0 (Short Circuit Ground/Open Circuit)
6	P0032	Sensor heater diagnosis #0 (Short Circuit Battery)
7	P0107	MAP sensor diagnosis (Short Circuit Ground/Open Circuit)
8	P0108	MAP sensor diagnosis (Short Circuit Battery)
9	P0112	Intake air temperature sensor diagnosis (Short Circuit Ground)
10	P0113	Intake air temperature sensor diagnosis (Short Circuit Battery/Open Circuit)
11	P0114	Electrical intake air temperature intermittent diagnosis (failure)
12	P0117	Coolant Temperature Sensor (Short Circuit Ground)
13	P0118	Coolant Temperature Sensor (Short Circuit Battery/Open Circuit)
14	P0119	Coolant temperature intermittent diagnosis (failure)
15	P0121	TPS position sensor adaptation diagnosis (out of range)
16	P0122	Throttle Position Sensor 1 (Short Circuit Ground/Open Circuit)
17	P0123	Throttle Position Sensor 1 (Short Circuit Battery)
18	P0131	Lambda sensor #0 diagnosis (Short Circuit Ground)
19	P0132	Lambda sensor #0 diagnosis (Short Circuit Battery)
20	P0133	Lambda sensor #0 diagnosis (Open Circuit)
21	P0171	Lambda control diagnosis #0 (too high)
22	P0172	Lambda control diagnosis #0 (too low)
23	P0217	Engine coolant over temperature protection diagnosis
24	P0219	Engine over speed detection diagnosis
25	P0231	Electric fuel pump diagnosis (Short circuit Ground/Open Circuit)
26	P0232	Electric fuel pump diagnosis (Short Circuit Battery)
27	P0261	Injection valve diagnosis #0 (Short Circuit Ground/Open Circuit)
28	P0262	Injection valve diagnosis #0 (Short Circuit Battery)
29	P0264	Injection valve diagnosis #1 (Short Circuit Ground/Open Circuit)
30	P0265	Injection valve diagnosis #1 (Short Circuit Battery)
31	P0351	Ignition diagnosis #0 (Short Circuit Battery)
32	P0352	Ignition diagnosis #1 (Short Circuit Battery)
33	P0370	Loss of synchronization diagnosis
34	P0371	Crankshaft sensor diagnosis
35	P0373	Crankshaft sensor diagnosis
36	P0462	FUEL sensor diagnosis (Short Circuit Ground)
37	P0463	FUEL sensor diagnosis (Short Circuit Battery/Open Circuit)
38	P0484	Cooling fan diagnosis (Short Circuit Battery)
39	P0485	Cooling fan diagnosis (Short circuit Ground/Open Circuit)
40	P0560	Battery voltage diagnosis (too low) _VBR
41	P0561	Battery voltage diagnosis (too high) _VBR

42	P0562	Battery voltage diagnosis (too low) _VBK
43	P0563	Battery voltage diagnosis (too high) _VBK
44	P0608	Reference voltage diagnosis (Short Circuit Battery)
45	P0609	Reference voltage diagnosis (Short Circuit Ground/Open Circuit)
46	P0615	Starter 1 diagnosis (Open Circuit)
47	P0616	Starter 1 diagnosis (Short Circuit Ground)
48	P0617	Starter 1 diagnosis (Short Circuit Battery)
49	P0630	VIN coherence
50	P0651	MIL diagnosis (Short Circuit Ground/Open Circuit)
51	P0652	MIL diagnosis (Short Circuit Battery)
52	P1352	Ignition diagnosis #0 (Short Circuit Ground/Open Circuit)
53	P1353	Ignition diagnosis #1 (Short Circuit Ground/Open Circuit)
54	P1508	Stepper motor diagnosis (Short Circuit Ground/Open Circuit)
55	P1509	Stepper motor diagnosis (Short Circuit Battery)
56	P1615	Starter 2 diagnosis (Open Circuit)
57	P1616	Starter 2 diagnosis (Short Circuit Ground)
58	P1617	Starter 2 diagnosis (Short Circuit Battery)

## Engine Oil

Your machine is factory-filled with Intimidator SYN 10W-40. This is the recommended engine oil. Always check and change the oil at intervals outlined in the periodic maintenance chart.

Pay attention to the oil level. A rise in oil level during cold weather can indicate contaminant collection in the oil sump or crankcase. Change oil immediately if the oil level begins to rise. Monitor the oil level, and if it continues to rise discontinue use and determine the cause or see your dealer.

### Oil Check

The oil dipstick and fill tube are located on the side of the engine. To check the oil:

1. Ensure the vehicle is parked safely on a level surface.
2. Start the engine and allow to idle for several minutes.
3. Shut down the engine. Wait several minutes to allow oil to flow down to the crankcase.
4. Unscrew and remove the dipstick. Wipe clean with a clean rag.
5. Re-insert the dipstick and screw it down fully.
6. Remove it again and observe how far up the dipstick the oil appears.
7. Add oil as necessary. Do not overfill.
8. Reinstall the dipstick. Screw down fully.

## Engine Oil and Filter Change

### Warning:

- Hot oil can cause burns to skin.

Always change the oil and filter at the intervals outline in the periodic maintenance chart. Always change the oil filter when changing the oil (except for the initial change at 12 hours). You will also need to replace the gasket ring on the drain plug screw.

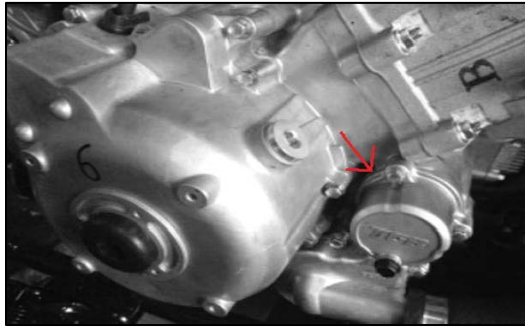

**Figure 20: Oil Filter Location**

1. Ensure the vehicle is parked safely on a level surface.
2. Start the engine and allow to idle for several minutes. If your engine is warm, this step is not necessary.
3. Shut down the engine. Allow several minutes for oil to flow down to the crankcase and cool slightly.
4. Place a drain pan under the engine drain plug area.
5. Wipe the drain plug and surrounding area with a clean rag.
6. Unscrew the drain plug and discard the gasket ring.
7. Remove the dipstick and allow oil to drain completely from the crankcase.

### Note:

- Observe the condition of the oil. It gives insight into the health of the engine. If there is debris present, it could be an indication of an issue within the engine. Check the engine to correct any issues immediately.
8. Clean the magnetic drain plug and install a new gasket ring onto the plug.
  9. Once the oil has completely drained, remove and replace the oil filter, hand tighten  $\frac{1}{4}$  turn past gasket contact with the housing.
  10. Reinstall the drain plug and torque to 17 ft/lb.
  11. Refill engine with Intimidator SYN 10W-40. Reference the specific engine manual for specific volumes.
  12. Once full, check the oil level with the dipstick.
  13. Start the engine and idle for several minutes to ensure that the filter and drain plug are not leaking.
  14. Double check oil level, shut down the engine.
  15. Dispose of used oil and filter per your local environmental regulations.

## Spark Plug Inspection

### Warning:

- Hot exhaust system and engine can cause burns.

Spark plug condition is indicative of engine operation. The spark plug firing end condition should be read after the engine is warmed up and the vehicle is driven at higher speeds. Immediately check the spark plug for color.

1. Ensure that the vehicle is safely parked on a flat surface.
2. Remove the seat and the spark plug cap.
3. Remove the spark plug by rotating it counterclockwise.
4. Observe the spark plug.
  - a. A normal plug insulator tip is gray, tan, or light brown, few combustion deposits, and the electrodes in good condition. If the tip is white, overheating has occurred. Improper spark plugs or incorrect throttle body adjustments can cause overheating.
  - b. A spark plug that is wet fouled will have a black insulator tip with a damp oil film covering the firing end. Excessive oil or incorrect throttle body adjustments can wet foul spark plugs.
5. Reinstall the plug by inserting it into its housing and rotating it clockwise until tight.

## Cooling System

### Danger:

- Radiator coolant is under pressure when the vehicle is hot. Escaping steam can cause burns.
- NEVER remove the radiator pressure cap while the engine is warm or hot.
- Always allow the engine to cool before removing the pressure cap.

### Notice:

- Do not travel through water deeper than 12 inches, or the center cap of the wheels. Water can enter the engine and damage essential components.
- Driving through tall grass or leaves can cause debris to build up on the engine fan, impeding engine cooling. Frequently check to ensure that the engine fan is free of debris.

Your vehicle's cooling system consists of an aluminum radiator with a pressure cap, overflow bottle, and connecting hoses which attach to the engine. As coolant operating temperature increases, the coolant heats, expands, and is forced out of the radiator past the pressure cap, and into the overflow bottle. As coolant temperature decreases, the coolant cools, contracts, and is drawn back up from the tank, past the pressure cap, and into the radiator.

Some coolant level drop on new vehicles is normal as the system is purging itself of trapped air. Observe coolant levels and maintain as recommended by adding coolant to the overflow bottle.

### **Adding or Changing Coolant**

It is recommended that coolant be drained and replaced every two years. Use a premixed, ready-to-use antifreeze that consists of 50% antifreeze and 50% distilled water. Do not dilute premixed antifreeze with water. Keep the overflow bottle filled to the recommended level.

### **Air Intake Screen**



**Figure 21: Air Intake Screen**

### **Notice:**

- Use of a pressure washer to clean the air intake screen may cause damage to the screen. If the screen is damaged it must be replaced.
- Contact your authorized dealer for a replacement.

The intake to the machine's engine and CVT is protected by a hydrophobic screen. To clean the screen:

1. Raise the cargo box to access the intake
2. Remove the screws holding the hydrophobic screen to the intake box.
3. Use a regular hose to flush any dirt, dust, or debris from the screen.
4. Allow the screen to dry and then re-attach it to the intake box with the stock screws.

## Radiator and Cooling Fan

Always keep the radiator screen clean and free of mud and debris. Do not obstruct or deflect air flow through the radiator by installing unauthorized accessories in front of the radiator or behind the cooling fan. Interference with the radiator air flow can lead to overheating and consequent engine damage. Do not spray the radiator with a high-pressure hose, as it could damage the radiator fins and impair their effectiveness.

The electric cooling fan is controlled by a temperature switch and will automatically turn on when needed. Periodically check the fuse and fan to ensure its proper operation.

## Air Filter

Always change the air filter at intervals outlined in the periodic maintenance chart. Service the air filter more frequently if the vehicle is operated in wet or dusty conditions, or if the vehicle is operated at high throttle for extended periods. The filter is located under the seat on the driver's side.

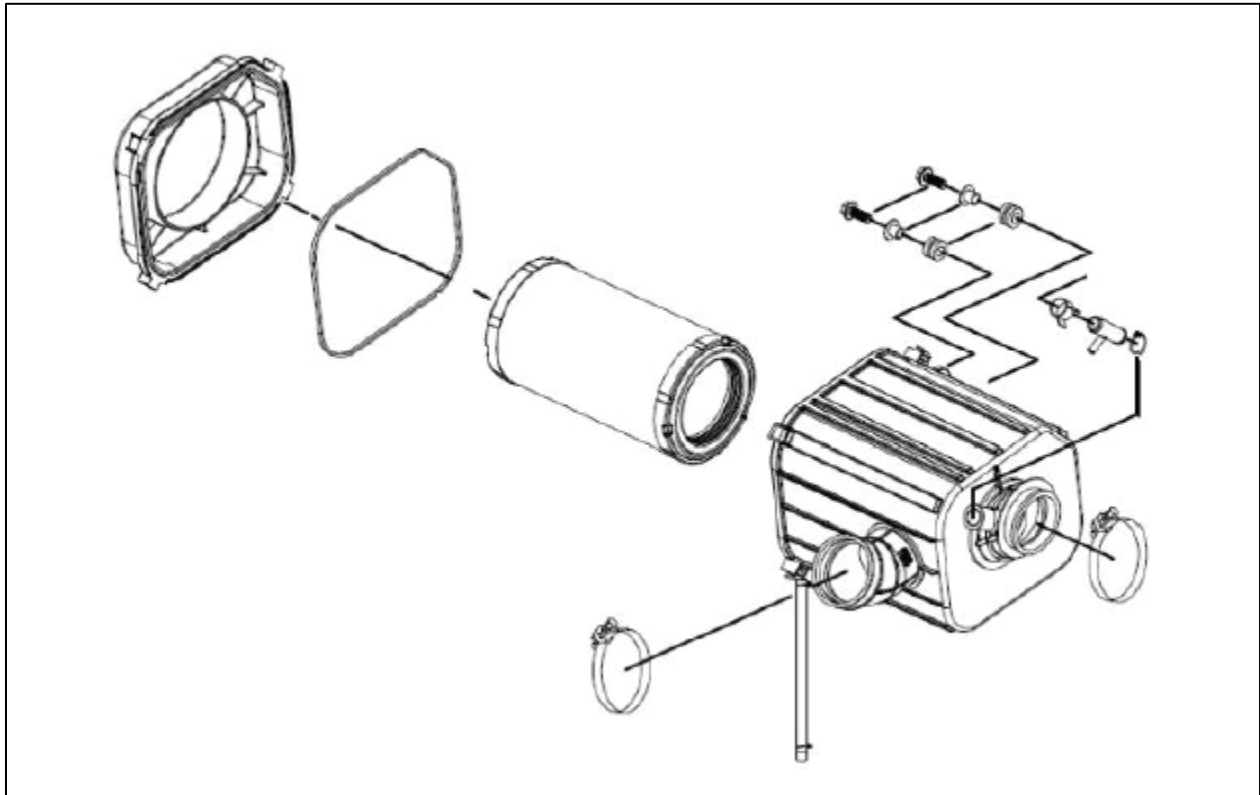

**Figure 22 Air Filter Box**

To change the air filter:

1. Unhook the clamps and remove the cover.
2. Turn and pull the filter to remove it.
3. Press new filter onto the air filter mount.
4. Replace the cover and re-attach the four clamps.

## Transmission and Gearbox

Always check and change the transmission oil at the intervals outlined in the periodic maintenance chart. Refer to the lubrication and fluid recommendations chart for type and capacities.

### Gearbox Oil Change

The gearbox oil drain plug is located on the underside of the machine.

1. Ensure that the vehicle is safely parked on a flat surface.
2. Place a drain pan under the gear case.
3. Remove the gear oil drain bolt and its washer, and allow the oil to drain completely.
4. Clean and reinstall the drain plug and washer. Tighten to a torque of 18 ft/lb.
5. Remove the breath hose and add the recommended oil (see Lubricant section).
6. Reinstall the breath hose and the fill plug.
7. Check for leaks.
8. Dispose of lubricant in accordance with local regulations.

## Adjusting the Shifter Linkage

### Warning:

- Your vehicle's gearshift lever comes properly adjusted from the factory so that the "Park" gear is fully engaged and will not slip.
- During every pre-ride inspection ensure that the gearshift lever is fully engaged into "Park" and does not slip out of gear.
- Have your authorized dealer annually inspect, lubricate, adjust, or replace the shifter cable.

If the transmission shifting lever on the dash is not fully engaging into "Park" or "Low," it needs to be adjusted. First, the distance out of alignment must be established, and then the system will need to be adjusted.

To establish alignment:

1. Ensure that the machine is safely parked on flat, level ground with the ignition off. Place chocks to the front and rear of the wheels.
2. Turn the ignition key to the "ON" position, but do not start the engine.
3. Depress the brake pedal fully. With two hands, carefully move the shifter lever upwards until an exclamation point (!) displays on the gauge.



**Figure 23: Carefully Moving Shifter**

When the system is operating properly, the exclamation point will display when the shift lever is directly on the tooth above the slot for “Neutral” gear. If the exclamation point displays when the lever is just moved out of the neutral slot, or does not display until the lever is almost in the slot for “Reverse,” the shifter must be adjusted.

To adjust the shifter:

1. Ensure that the vehicle is safely parked on a level surface with the ignition off.
2. Locate the shift lever Heim under the hood, directly to the left of the steering column as viewed from the front of the machine.



**Figure 24: Shift Lever Heim**

3. Remove the Heim from the shifter lever assembly by removing the retaining nut.
4. Thread the Heim either clockwise or counterclockwise depending on whether the shifter needs to be adjusted up or down as established by the alignment test. Adjust the Heim in increments of  $\frac{1}{2}$  turn.
5. Re-attach the Heim to the shifter assembly, and test the shifting system.

After every 2 or 3 adjustments, start the vehicle and travel forward 10 feet, then backwards 10 feet before attempting the next adjustment. This will allow the system to relieve any excess pressure.

If shifting problems persist, or the vehicle continues to slip out of “Park,” take it to an authorized Intimidator dealer for service.

## Differentials

The front and rear differentials are the transfer point from the engine to the axles. Check and change the differential oil at the intervals outlined in the periodic maintenance chart. Maintain the oil level even with the bottom thread of the fill plug hole. Refer to the front or rear differential specifications on the oil lubrication and fluid recommendations chart for type and capacities.

### Differential Oil Check

On the front differential, the check/fill plug is located on the driver’s side facing the rear. On the rear differential, the check/fill plug is located on the passenger side facing the wheel. To check the differential oil:

1. Ensure that the vehicle is safely parked on a flat surface.
2. Place the gearbox into “Park.”
3. Remove the fill plug. Check the oil level.
4. Add oil as needed.
5. Reinstall the fill plug.

### Differential Oil Change

On the front differential, the drain plug is located on the bottom in the center. On the rear differential, the drain plug is located on the passenger side. To change the differential oil:

1. Ensure that the vehicle is safely parked on a flat surface.
2. Place the gearbox into “Park.”
3. Place a drain pan under the drain plug.
4. Remove the fill plug.
5. Remove the drain plug. Allow the oil to drain completely.
6. Clean and reinstall the drain plug.
7. Fill with oil to the correct level.
8. Reinstall the fill plug.
9. Check for leaks.
10. Dispose of lubricant in accordance with local regulations.

## Continuously Variable Transmission (CVT)

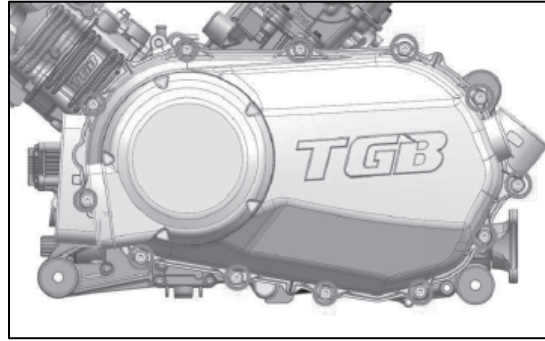

**Figure 25: CVT Housing**

### **Danger:**

- Only qualified personnel are to perform installation, maintenance, adjustments, and repair operations on the variable speed transmission system.
- Your vehicle is equipped with a CVT which rotates at high speed, creating large amounts of force on clutch components.
- As the owner, you have the responsibility to make sure that this system remains safe.
- Turn the vehicle off and remove the ignition key when servicing any part of the CVT system, engine, or any component accessible under the seat.
- Do not modify any components of the CVT system.
- Always follow all recommended maintenance procedures.
- Always look for and remove debris inside and around the clutch and vent system when replacing the belt.

### **Notice:**

To help minimize belt slippage and increase the life of the CVT belt, shift to “Low” gear while operating at slower speeds, hauling heavy cargo, or towing a trailer.

### **CVT Belt Replacement/Debris Removal**

#### **Danger:**

- Failure to remove all debris when replacing the belt could result in vehicle damage and severe injury.

If the belt fails, always clean any debris from the duct, the clutch, and all engine compartments when replacing the belt:

1. Ensure that the vehicle is safely parked on a flat surface with the engine off and the key removed from the ignition.
2. Remove the seat.

3. Remove the CVT cover.
4. Remove all debris wrapped in and around the CVT system and air duct passage.
5. Check for signs of damage to seals on the transmission and engine. See your dealer promptly for service if any seals appear to be damaged.
6. Replace the CVT cover and the seat.

## CVT Drying

Use the following instructions to dry out a wet CVT before operating:

1. Ensure that the vehicle is safely parked on a flat surface with the engine off.
2. Remove the CVT drain bolt
3. Allow all water to drain from the CVT.
4. Reinstall the drain bolt.

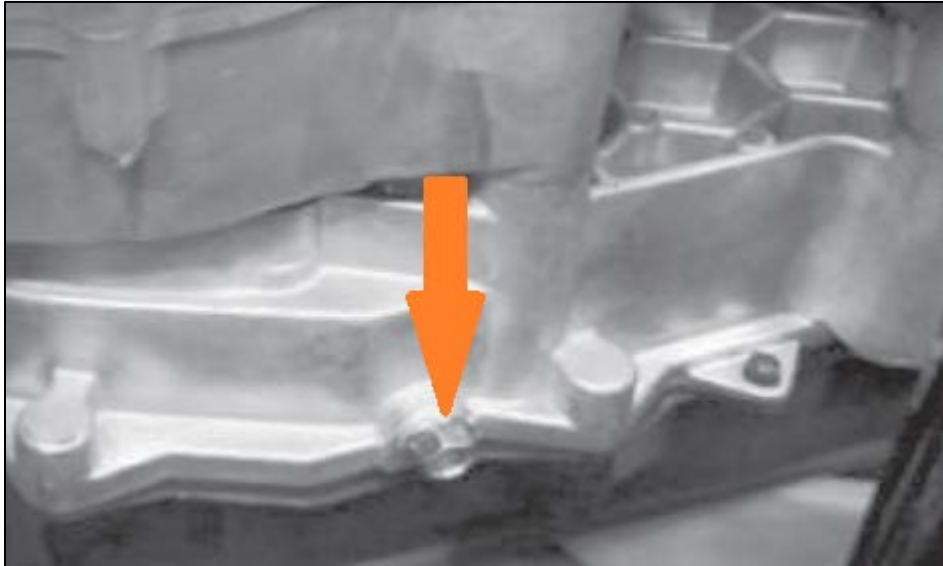

**Figure 26: CVT Drain Bolt Location**

### Note:

- If any debris entered the CVT, the CVT must be cleaned and inspected.
5. Apply the brakes and start the engine.
  6. Apply varying throttle for 15 seconds to expel the moisture and air-dry the belt and clutches. Do not hold the throttle at maximum.
  7. Allow the engine RPM to settle to idle speed.
  8. Shift to “Low” gear.
  9. Drive slowly. Test for belt slippage. If the belt slips, begin the drying process from step 1.
  10. If the belt continues to slip after repeating the process several times, take the vehicle to your authorized dealer.

## Vehicle Submerged in Water

### Notice:

- If your vehicle becomes immersed in water, major engine damage can result.
- Intimidator warranty does not cover vehicles submerged in water over the floor board.
- If your vehicle does become submerged above the engine, thorough inspection is necessary.
- It is recommended that you take the vehicle to your dealer before starting the engine.

If it is impossible to take your vehicle to a dealer before starting the engine, follow these steps:

1. Tow the vehicle to dry land.
2. Dry any water present in the air box. Filter replacement is required if water is present.
3. Thoroughly dry the air filter.
4. Drain and replace the engine oil.
5. Remove the spark plugs. Turn the engine over several times using the ignition key.
6. Dry the spark plugs, then reinstall them. If possible, replace the fouled plugs with new ones.
7. Attempt to start the engine. If it does not start, repeat the drying procedure.
8. Immediately take the vehicle to your dealer for service.

## Throttle System

If the throttle pedal has excessive play due to either cable stretching or mis-adjustment, it will cause a delay in throttle response or may prevent the throttle from opening fully especially at low engine speed. If the throttle pedal has no play, the throttle may be hard to control and the idle speed may be erratic. Check the throttle play periodically and adjust if necessary.

### Throttle Pedal Inspection

To inspect and adjust the throttle play:

1. Ensure that the vehicle is safely parked on flat surface.
2. Start the engine.
3. Measure the distance that the throttle pedal moves before the engine begins to increase in RPM. This movement should be around ½”.

If play is incorrect:

4. Locate the throttle cable jam nuts under the hood, against the firewall.
5. Loosen and adjust the jam nuts on the cable.
6. Test the play after each adjustment until the movement is correct.

# Battery



Figure 27: Battery Location Under Hood

## Danger:

- The battery emits explosive gases. Keep away from any source of flame or spark.
- The battery contains sulfuric acid which can cause serious chemical burns. Wear goggles and rubber/latex gloves to avoid any chemical contact with skin.
- If the acid comes into contact with skin or eyes, flush the area with plenty of clean water and immediately seek medical assistance.

## Battery Maintenance

- Check terminals monthly.
- Dielectric grease or petroleum jelly will prolong battery terminal life span.
- When connecting the battery, connect the red lead (+) first, and then the black lead (-). Reversing the leads will harm your machine.

## Battery Charging

- Keep the work area well ventilated
- Disconnect the battery from the vehicle and remove it from the vehicle.
- Use a charger that supplies 1.8A. 5-10 hours is sufficient.
- The maximum charging rate is 9A for 1 hour.

## Battery Status

Charge %	Voltage	Action	Charge Time
100%	12.8-13V	None	None
75-100%	12.5-12.8V	May need charge	3-6 hours
50-75%	12.0-12.5V	Needs charge	5-11 hours
25-50%	11.5-12.0V	Needs charge	12+ hours
0-25%	< 11.5V	Requires charge from desolating charger	See dealer

## Jump Starting

### Danger:

- The battery contains sulfuric acid that can cause severe burns and produce highly explosive hydrogen gas.
- Do not touch the positive and negative cables together while they are connected to the battery.
- Do not lean over the battery.
- Do not attempt to jump start a frozen battery. It may explode.
- Do not reverse the polarity of the jumper cable leads.

### Notice:

- Do not operate the starter continuously for more than 5 seconds. The starter can overheat and the battery charge will drop.
- Wait 15 seconds between each attempt at ignition to give the starter time to cool and for the battery to recover.

If your vehicle's battery is depleted, it should be removed and charged. If this is not practical, a 12-volt booster battery and jumper cables may be used to start the engine. To jump-start your machine:

1. Ensure that the dead vehicle and the donor vehicle are parked within jumper cable range safely with both engines off.
2. Raise the hoods of both vehicles.
3. Connect the leads to the batteries of each vehicle in this sequence.
  - a. Red lead to positive terminal of dead vehicle
  - b. Red lead to positive terminal of donor
  - c. Black lead to negative terminal of dead vehicle
  - d. Black lead to negative terminal of donor.
4. Start the engine of the donor vehicle and allow a minute or two of idle to allow the dead battery to charge.
5. Attempt to start the dead vehicle.
6. If the vehicle starts, remove the leads in the opposite sequence of step 3.
7. If the vehicle does not start allow more time for the battery to charge.
8. If more than 10 minutes elapse and the dead vehicle still will not start, take your machine to your authorized dealer for assistance.

## Battery Storage

Whenever the vehicle is not in use for any extended period of time, disconnect the negative battery cable from the battery after ensuring that the battery is fully charged.

A battery tender can remain connected to the battery during the storage period.

## Headlights

The headlights are controlled by a three-way switch in the dash. The LED light strips are daytime running lights. The outside set of lights are low-beams, while the inside set are the high-beams.

## CV Joint Boots

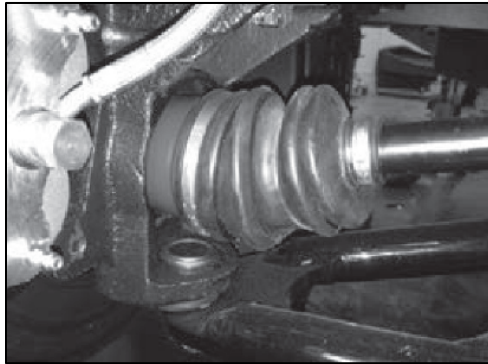
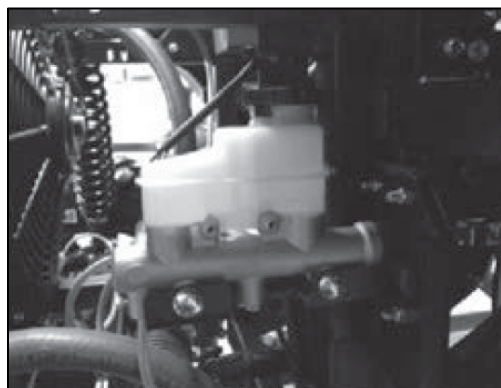

**Figure 28: Joint Boot**

In accordance with the periodic maintenance chart, inspect the joint boots on the front axles, rear axles, tie rod ends, and steering rack for damage or deterioration. Replace any damaged boot and be sure that the joints are greased.

## Brakes

The brakes system consists of hydraulic disc brakes activated by the brake pedal.



**Figure 29: Brake System Master Cylinder**

## **Brake Fluid**

Inspect the brake fluid level before each operation. Always keep the fluid level between the minimum and maximum fill line on the reservoir. Change the brake fluid either every two years, or any time the fluid becomes contaminated. To change the brake fluid:

1. Ensure that the vehicle is safely parked on a flat surface.
2. Inspect the brake fluid level at the reservoir located in the driver's side wheel well. The level should be between the MAX and MIN indicator lines.
3. If the fluid level is low, remove the cap until it falls between the indicators.
4. Reinstall the cap.
5. Apply the brake forcefully for a few seconds and inspect for fluid leakage around the fittings.

## **Brake Pressure Switch and Safety Switch**

For safety, the brake must be applied to start the Intimidator. The brake pressure switch is located on the master cylinder.

## **Brake Inspection**

To inspect the brake system:

1. Check all hoses and fittings for fluid leaks.
2. Check the brake pedal for excessive travel or a spongy feel.
3. Check the friction pads for wear, damage and looseness.
4. Inspect the brake disc spline and pad wear surface for excessive wear.
5. Change pads when worn to 3/64" (1 mm)

## **Tires**

### **Danger:**

- Installation of non-standard tires, use of oversized tires, or use of different tread patterns can change or impair the handling of the vehicle and result in severe injury.

Tire construction characteristics and inflation pressure can greatly influence vehicle handling. Intimidator recommends that you replace tires with standard OEM tires. It is also important that all tires on the machine are of the same type and height, inflated to the recommended pressure.

### **Tire Tread Depth**

Replace your tires when the tread depth is worn to 1/8".

### **Lug Nuts**

Torque lug nuts to 65 ft/lb.

## Wheel Alignment

### Notice:

- Installing unauthorized accessories, such as larger tires or a lift kit, may damage the vehicle and cause control problems.

It is recommended that tire alignment be performed by an authorized dealer. To adjust tire alignment:

1. Ensure that the vehicle is safely parked on flat surface.
2. Center the steering wheel
3. Measure the distance between the centerlines on the very front of the front tires at the height of the axle.
4. Measure the distance between the centerlines on the back of the front tires at the height of the axle.
5. The front distance should be 0" to ¼" shorter than the rear distance.
6. Adjust the tie rod to correct any discrepancy.

## Steering

### Steering Wheel Inspection

Check the steering wheel for the specified free play and smooth operation at the intervals outlined in the periodic maintenance chart. To inspect the steering wheel:

1. Ensure that the vehicle is safely parked on a flat surface.
2. Lightly turn the steering wheel left and right. There should be no more than ½" of free play.
3. If there is excessive free play, strange noises, or the steering feels rough, have the steering system inspected by an authorized dealer.

### Steering Wheel Adjustment

To center the steering wheel:

1. On level ground, drive straight forward for 30 feet. This is most easily done by driving on a painted line, next to a wall or some other straight object.
2. Stop the vehicle and shift the transmission to "Park."
3. Remove the steering wheel cap to expose the steering wheel nut.
4. Remove the nut with the appropriately sized socket.
5. With your hands or a rubber mallet, gently knock the back of the steering wheel towards the seat until it is removed. Do not use excessive force or the steering wheel may suffer damage or come off quickly. Do not turn the steering wheel or allow the tires to turn.
6. Reinstall the steering wheel to center position.
7. Reinstall the steering wheel nut, and then the cap.

## Power Steering (if equipped)

### Notice:

- When reaching the maximum turn angle while steering the machine, do not hold the maximum angle for longer than 3 seconds to avoid overheating the electric motor and controller.

The Intimidator GC1K Stage 2 and Stage 3 come equipped with power steering made by Demon Powersports. If the system is not operating as intended, follow the troubleshooting procedures below.

To troubleshoot the power steering system:

1. Check all connections and fuses.
2. Check the LED Diagnostic light for a blinking pattern.
  - a. Normally the light will turn on for one second and then turn off when the engine is started.
  - b. If the light remains on there is an incorrect connection in the system, refer to the Fault Diagnosis Table below.
  - c. If there is a malfunction, the system will create a code to identify the problem. Each fault code is displayed by a series of flashes.
  - d. If the light pattern does not indicate a fault code, the wiring system must be checked with a multimeter.











### Fault Code Flashes

Every fault code is composed of double digits. Each long flash represents a multiple of 10 and is 2 seconds in length. Each short flash represents a single digit and is 1 second in length. There is a 3 second space between the long flashes and the short flashes.

Example:

Long flash - long flash – space - short flash = fault code 21

## Fault Code Table

Code	Diagnosis Content	Fault Code Wave
21	Main torque sensor disconnection	
22	Main torque sensor output error (voltage too high or low)	
23	Vice torque sensor disconnected	
24	Vice torque sensor output error (voltage too high or low)	
25	Main and vice torque difference is too large	
26	Main torque sensor inner fault	
32	Motor disconnected	
33	Current of ECU is over the limit	
34	Once side of motor has no assistance	
35	Current sensor zero offset is too large	
36	Motor voltage abnormal	

## Sensor Problem Troubleshooting Chart

Code	Diagnosis Content	Suggestions	Solutions
21	Main torque sensor disconnection	<ol style="list-style-type: none"> <li>1. Unplug and re-plug all wires</li> <li>2. Check voltage of each wire by multimeter</li> <li>3. Test with new ECU</li> </ol>	<ol style="list-style-type: none"> <li>1. Ensure proper wire connections</li> <li>2. Replace ECU</li> <li>3. Change motor</li> </ol>
22	Main torque sensor output error (voltage too high or low)		
23	Vice torque sensor disconnected		
24	Vice torque sensor output error (voltage too high or low)		
25	Main and vice torque difference is too large		

## ECU Problem Troubleshooting Chart

Code	Diagnosis Content	Suggestions	Solutions
26	Main torque sensor inner fault	Check motor, if motor is good test with new ECU	Replace motor, replace ECU
32	Motor disconnected	Test with new ECU	Replace ECU
34	Once side of motor has no assistance		
35	Current sensor zero offset is too large		

## Washing and Maintaining Appearance

### Notice:

- High water pressure may damage components including wheel bearings, radiator, transmission seals, brakes, plastic panels, safety labels, electrical switches, electronic components, and wiring.
- Wash the vehicle by hand or with a garden hose using mild soap.
- Certain products, including insect repellents and chemicals, will damage plastic surfaces. Do not use these types of products.
- Mud can stain the vehicle's seat and plastic. Immediately wash mud off of the vehicle with mild soap and water.

Keeping your vehicle clean will not only improve its appearance, but it can also extend the life of various components. Below are some guidelines for keeping your Intimidator clean:

- Avoid the use of harsh or abrasive cleaners that can scratch the finish.
- Use automotive adhesive remover to clean sticker residue from plastic.
- Do not use a pressure washer to clean the vehicle.
- Always use clean microfiber cloths, towels, and pads for cleaning and polishing.
- Grease all zerk fittings immediately after washing and run the engine for several minutes to evaporate any water that may have entered the engine or exhaust system.
- Replace any safety labels damaged by cleaning immediately.
- Use extra caution around critical components such as air intakes or electronics.

# Troubleshooting

Symptom	Cause	Action
<b>Engine is difficult to start or will not start</b>	Key switch is not in the proper position	Make sure the key is in "ON" position
	Wiring	Clean corroded connections, tighten loose connections
	Starter switch or solenoid	By-pass switch or solenoid with a jumper wire. If starter cranks normally, replace faulty components
	No fuel, or low fuel	Replenish fuel
	Improper or stale fuel	Replace fuel, consult your dealer
	Water or dirt in fuel system	Replace fuel, consult your dealer
	Air in the fuel system	Bleed fuel system
	Fuel hose or fuel filter clogged or damaged	Clean/replace fuel lines, consult your dealer
	Air filter clogged	Clean/replace air filter
	Defective spark plug	Adjust spark plug gap, check spark plug wire connection, replace spark plug
	Improper engine oil viscosity	Change oil to proper viscosity
	Weak battery	Clean battery cables/terminals, charge battery, remove the battery for storage
	Brake pedal not engaged	Apply pressure to brake when starting
	Brake pressure switch malfunction	Replace brake switch
<b>Insufficient engine power</b>	Fuse blown	Replace fuse
	Dead battery	Charge/replace battery
	Loose battery/solenoid connections	Inspect/tighten all connections
	Insufficient/dirty fuel	Inspect fuel system, replace fuel/fuel filter
<b>Engine stops suddenly</b>	Clogged air cleaner	Clean/replace air cleaner
	Cold engine	Allow time for engine to warm
	Cold engine	Allow time for engine to warm
	Insufficient fuel	Replenish fuel
	Fuel pump malfunction	Check wire connections, replace pump
<b>Rough running engine</b>	Cold engine	Allow time for engine to warm
	Defective spark plug	Adjust spark plug gap, replace spark plug
	Defective high-tension cord	Allow time for engine to warm
	Defective ignition coil	Consult your dealer
	Clogged/damaged fuel hose	Clean/replace fuel lines, consult your dealer
	Improper/stale fuel	Replace fuel

	Clogged air filter	Clean/replace air filter
<b>Exhaust fumes are colored (black, dark gray)</b>	Overloaded	Reduce cargo/tow load
	Low grade fuel	Refill with recommended fuel
	Clogged air filter	Clean/replace air filter
<b>Exhaust fumes are colored (white, blue)</b>	Excessive engine oil	Drain oil to specified level
	Piston ring is worn/stuck	Consult your dealer
<b>Overheating Engine</b>	Overloaded	Reduce speed, use low gear, reduce load
	Insufficient engine oil	Replenish engine oil
	Dirty engine	Remove mud/debris from engine
	Air intake/fan blocked	Remove mud/debris from air intake
<b>Engine diagnostic light on</b>	Engine issue	Consult your dealer
<b>Engine will not idle</b>	Defective spark plug	Adjust spark plug gap, replace spark plug
	Cold engine	Allow time for engine to warm
	Dirty fuel injectors	Consult your dealer
<b>Difficult to shift</b>	Engine RPM too high	Consult your dealer
	Stretched shift cable	Adjust/replace shift cable
	Dirty/rusty shift cable	Clean/replace shift cable

## CVT Troubleshooting

Symptom	Cause	Action
<b>Accelerated CVT belt wear</b>	Improper gear for towing/plowing	Use low gear
	Heavy payload	Use low gear
	Steep inclines	Use low gear
	Stuck in mud/snow, climbing over large obstacles	Use low gear, fast throttle technique
	Aggressive driving	Stop vehicle, allow belt to cool
	Insufficient warm-up in cold weather	Idle engine for 5 minutes, in "Neutral," apply 5, 1/8 throttle short bursts to warm system
<b>Acceleration not smooth from stop</b>	Cold engine	Allow time for engine to warm

## Battery Troubleshooting

Symptom	Cause	Action
<b>Starter does not function</b>	Overused battery	Charge/replace battery
	Dead battery	Charge/replace battery
	Poor terminal connection	Clean/tighten connections
<b>Terminals appear white</b>	Insufficient electrolyte	Add distilled water to proper level, charge battery
	Overused battery	Charge/replace battery
<b>Recharging is impossible</b>	Expired battery	Replace battery
<b>Severely corroded terminals</b>	Poor terminal connection	Clean terminals, tighten connections, apply dielectric grease
<b>Low battery electrolyte</b>	Failure in electrolytic cells	Replace battery

# Storage

---

## **Notice:**

- Do not store the vehicle in direct sunlight.

## **Preparation for Storage:**

1. Thoroughly clean the entire vehicle.
2. Run the engine for five minutes to warm the oil. If you do not intend to use a fuel stabilizer, run the engine outdoors until the motor stops from lack of fuel. If the vehicle will be stored with fuel in the tank, fill the tank completely and add an appropriate fuel stabilizer.
3. Change the engine oil and oil filter.
4. Remove the spark plugs and pour approximately 1 oz. of engine oil into the cylinder(s). Replace the plugs and crank the engine several times with the ignition key to distribute the oil evenly.
5. Place boards under the tire to keep moisture away from the rubber.
6. Lubricate throttle cable.
7. Remove the battery and store it where it will not be exposed to direct sunlight, moisture, or freezing temperatures.
8. Tie a plastic bag over the exhaust pipe, CVT intake, and the CVT exhaust to prevent moisture or small animals from taking up residence.
9. Put a cover over the vehicle to keep dust and dirt from collecting.

## **Removal from Storage:**

1. Remove the cover
2. Remove the plastic bags from the exhaust pipe, CVT intake, and the CVT exhaust.
3. Clean the battery terminals, charge the battery if necessary, and install it into the vehicle.
4. Check the spark plugs for tightness and that the wires are connected snugly.
5. Fill the fuel tank with fresh fuel.
6. Check each point listed in the “Pre-Ride Checklist” at the end of this manual.
7. Lubricate any fixtures as required.

# Transporting Your Intimidator

---

## **Danger:**

- When trailering your vehicle, always put the transmission in “Park” and secure the vehicle to the trailer by attaching the frame of the UTV to trailer using properly rated straps or chains.
- Do not attach a strap or chain to the suspension arms.

The best way to transport your Intimidator to different locations over the road is to load it onto a trailer or flatbed truck. Below are some considerations while transporting your machine:

- Use extra caution with any and all activities involved with loading, securing, transporting, and unloading your machine.
- Make sure that the trailer/truck is parked safely on flat ground and that the tires are immobilized.
- Do not use a ramp at an angle of more than 15 degrees.
- Use extra care when driving the UTV up and down the ramps.
- Ensure that the straps/chains used for securing the machine are rated sufficiently for the weight of the machine.

## Accessories

---

For a complete line of genuine Intimidator accessories, visit [www.baddawgaccessories.com](http://www.baddawgaccessories.com).

# Specifications

## GC1K Stage 1

<b>Core Components</b>	
Frame	Powder-Coated Fusion-Bonded Solid Steel Bridge
Body	Automotive Quality Acrylic Plastic
Front Tires	27x10x14 – 6 ply
Rear Tires	27x12x14 – 6 ply
Wheels	14" (35.6 cm) Wheels
Suspension	Dual A-Arm Independent
Steering	Rack and Pinion
Braking System	4-Wheel Hydraulic Disc
Parking System	2-Wheel Gear Lock
Bed Dump	Electric Dump
Shocks	Base Shocks
Seating	3 Occupant, Forward Facing Bench Seat
Auxiliary Power	Double USB Port
Display	4.3" (10.9 cm) Color Display
Hitch	2" (5.1 cm) Receiver Standard
Cargo Bed Space	35"x53"x13" (88.9cm x 134.6cm x 33cm)
Fuel Capacity	9 Gallons (34.1 L)
Warranty	1-year Bumper to Bumper
<b>Drive System</b>	
Displacement	997cc EFI Liquid Cooled
Bore x Stroke	92mm x 75mm
Compression Ratio	10.2:1
Carburetor	Electronic Fuel-Injected Throttle Body
Final Drive	Shaft Driven
Automatic CVT	Low/High/Neutral/Reverse/Park
Drive System	2WD, Electronic 4WD Selection
Cooling	Liquid
Starting	Electric Start
MAX Horsepower	83Hp (61.9 kW)
Fuel Type	87 Octane Gasoline (10% Ethanol Max) 91+
Engine Oil Type	Intimidator SYN 5W-40
Speed	Up to 60 MPH (96.6 KPH)
<b>Measurements</b>	
Curb Weight	1,834 lb. (831.9 kg)
Length	122" (309.9 cm)
Width	64" (162.6 cm)
Height	79.5" (201.9 cm)
Frame Clearance	11" (27.9 cm)
Suspension Travel	10" (25.4 cm)
Cargo Bed Capacity	1,000 lb. (453.6 kg)
Vehicle Payload	1,450 lb. (657.7 kg)
GVWR	3,300 lb. (1,496.9 kg)
Towing Capacity	2,500 lb. (1,134 kg)
<b>Safety</b>	
Protection	1.75" (4.5 cm) Diameter Tubing Five Piece ROPS
Front Protection	1.75" (4.5 cm) Diameter Tubing Bumper/Brush Guard
Occupant Restraint System	Rotomolded Doors
Passenger Restraints	3 Point DOT Approved Restraint Belts
Shift Indicator	5 Position Gear Indicator Display
Headlights	LED – Automotive Style High and Low Beam
Brake/Tail Light	Standard

## GC1K Crew Stage 1

<b>Core Components</b>	
Frame	Powder-Coated Fusion-Bonded Solid Steel Bridge Frame
Body	Automotive Quality Acrylic Plastic
Front Tires	27x10x14 – 6 ply
Rear Tires	27x12x14 – 6 ply
Wheels	14" (35.6 cm) Wheels
Suspension	Dual A-Arm Independent
Steering	Rack and Pinion
Braking System	4-Wheel Hydraulic Disc
Parking System	2-Wheel Gear Lock
Bed Dump	Electric Dump
Shocks	Heavy Duty Base Shocks
Seating	6 Occupant, Forward Facing Bench Seat
Auxiliary Power	Double USB Port
Display	4.3" (10.9 cm) Color Display
Hitch	2" (5.1 cm) Receiver Standard
Cargo Bed Space	35"x53"x13" (88.9cm x 134.6cm x 33cm)
Fuel Capacity	9 Gallons (34.1 L)
Warranty	1-year Bumper to Bumper
<b>Drive System</b>	
Displacement	997cc EFI Liquid Cooled
Bore x Stroke	92mm x 75mm
Compression Ratio	10.2:1
Carburetor	Electronic Fuel-Injected Throttle Body
Final Drive	Shaft Driven
Automatic CVT	Low/High/Neutral/Reverse/Park
Drive System	2WD, Electronic 4WD Selection
Cooling	Liquid
Starting	Electric Start
MAX Horsepower	83Hp (61.9 kW)
Fuel Type	87 Octane Gasoline (10% Ethanol Max) 91+ Recommended
Engine Oil Type	Intimidator SYN 5W-40
Speed	Up to 60 MPH (96.6 KPH)
<b>Measurements</b>	
Curb Weight	2,212 lb. (1,003.3 kg)
Length	157" (398.8 cm)
Width	64" (162.6 cm)
Height	79.5" (201.9 cm)
Frame Clearance	11" (27.9 cm)
Suspension Travel	10" (25.4 cm)
Cargo Bed Capacity	1,000 lb. (453.6 kg)
Vehicle Payload	1,450 lb. (657.7 kg)
GVWR	3,300 lb. (1,496.9 kg)
Towing Capacity	2,500 lb. (1,134 kg)
<b>Safety</b>	
Protection	1.75" (4.5 cm) Diameter Tubing Five Piece ROPS
Front Protection	1.75" (4.5 cm) Diameter Tubing Bumper/Brush Guard
Occupant Restraint System	Rotomolded Doors
Passenger Restraints	3 Point DOT Approved Restraint Belts
Shift Indicator	5 Position Gear Indicator Display
Headlights	LED – Automotive Style High and Low Beam
Brake/Tail Light	Standard

## GC1K Stage 2

<b>Core Components</b>	
Frame	Powder-Coated Fusion-Bonded Solid Steel Bridge Frame
Body	Automotive Quality Acrylic Plastic
Front Tires	28x10.5x14 – 8 ply Radial
Rear Tires	28x10.5x14 – 8 ply Radial
Wheels	14" (35.6 cm) Wheels
Suspension	Dual A-Arm Independent
Steering	Rack and Pinion
Braking System	4-Wheel Hydraulic Disc
Parking System	2-Wheel Gear Lock
Bed Dump	Electric Dump
Shocks	Base Shocks
Seating	3 Occupant, Forward Facing Bench Seat
Auxiliary Power	Double USB Port
Display	4.3" (10.9 cm) Color Display
Hitch	2" (5.1 cm) Receiver Standard
Cargo Bed Space	35"x53"x13" (88.9cm x 134.6cm x 33cm)
Fuel Capacity	9 Gallons (34.1 L)
Warranty	1-year Bumper to Bumper
<b>Drive System</b>	
Displacement	997cc EFI Liquid Cooled
Bore x Stroke	92mm x 75mm
Compression Ratio	10.2:1
Carburetor	Electronic Fuel-Injected Throttle Body
Final Drive	Shaft Driven
Automatic CVT	Low/High/Neutral/Reverse/Park
Drive System	2WD, Electronic 4WD Selection
Cooling	Liquid
Starting	Electric Start
MAX Horsepower	83Hp (61.9 kW)
Fuel Type	87 Octane Gasoline (10% Ethanol Max) 91+ Recommended
Engine Oil Type	Intimidator SYN 5W-40
Speed	Up to 60 MPH (96.6 KPH)
<b>Measurements</b>	
Curb Weight	1,873 lb. (849.6 kg)
Length	122" (309.9 cm)
Width	64" (162.6 cm)
Height	80.5" (201.9 cm)
Frame Clearance	12" (30.5 cm)
Suspension Travel	10" (25.4 cm)
Cargo Bed Capacity	1,000 lb. (453.6 kg)
Vehicle Payload	1,450 lb. (657.7 kg)
GVWR	3,300 lb. (1,496.9 kg)
Towing Capacity	2,500 lb. (1,134 kg)
<b>Safety</b>	
Protection	1.75" (4.5 cm) Diameter Tubing Five Piece ROPS
Front Protection	1.75" (4.5 cm) Diameter Tubing Bumper/Brush Guard
Occupant Restraint System	Rotomolded Doors
Passenger Restraints	3 Point DOT Approved Restraint Belts
Shift Indicator	5 Position Gear Indicator Display
Headlights	LED – Automotive Style High and Low Beam
Brake/Tail Light	Standard

## GC1K Crew Stage 2

<b>Core Components</b>	
Frame	Powder-Coated Fusion-Bonded Solid Steel Bridge Frame
Body	Automotive Quality Acrylic Plastic
Front Tires	28x10.5x14 – 8 ply Radial
Rear Tires	28x10.5x14 – 8 ply Radial
Wheels	14" (35.6 cm) Wheels
Suspension	Dual A-Arm Independent
Steering	Rack and Pinion
Braking System	4-Wheel Hydraulic Disc
Parking System	2-Wheel Gear Lock
Bed Dump	Electric Dump
Shocks	Heavy Duty Base Shocks
Seating	6 Occupant, Forward Facing Bench Seat
Auxiliary Power	Double USB Port
Display	4.3" (10.9 cm) Color Display
Hitch	2" (5.1 cm) Receiver Standard
Cargo Bed Space	35"x53"x13" (88.9cm x 134.6cm x 33cm)
Fuel Capacity	9 Gallons (34.1 L)
Warranty	1-year Bumper to Bumper
<b>Drive System</b>	
Displacement	997cc EFI Liquid Cooled
Bore x Stroke	92mm x 75mm
Compression Ratio	10.2:1
Carburetor	Electronic Fuel-Injected Throttle Body
Final Drive	Shaft Driven
Automatic CVT	Low/High/Neutral/Reverse/Park
Drive System	2WD, Electronic 4WD Selection
Cooling	Liquid
Starting	Electric Start
MAX Horsepower	83Hp (61.9 kW)
Fuel Type	87 Octane Gasoline (10% Ethanol Max) 91+ Recommended
Engine Oil Type	Intimidator SYN 5W-40
Speed	Up to 60 MPH (96.6 KPH)
<b>Measurements</b>	
Curb Weight	2,250 lb. (1,020.6 kg)
Length	157" (398.8 cm)
Width	64" (162.6 cm)
Height	80.2" (209.9 cm)
Frame Clearance	12" (30.5 cm)
Suspension Travel	10" (25.4 cm)
Cargo Bed Capacity	1,000 lb. (453.6 kg)
Vehicle Payload	1,450 lb. (657.7 kg)
GVWR	3,300 lb. (1,496.9 kg)
Towing Capacity	2,500 lb. (1,134 kg)
<b>Safety</b>	
Protection	1.75" (4.5 cm) Diameter Tubing Five Piece ROPS
Front Protection	1.75" (4.5 cm) Diameter Tubing Bumper/Brush Guard
Occupant Restraint System	Rotomolded Doors
Passenger Restraints	3 Point DOT Approved Restraint Belts
Shift Indicator	5 Position Gear Indicator Display
Headlights	LED – Automotive Style High and Low Beam
Brake/Tail Light	Standard

## GC1K Stage 3

<b>Core Components</b>	
Frame	Powder-Coated Fusion-Bonded Solid Steel Bridge Frame
Body	Automotive Quality Acrylic Plastic
Front Tires	30x10.5x15 – 8 ply Radial
Rear Tires	30x10.5x15 – 8 ply Radial
Wheels	15" (38.1 cm) Wheels
Suspension	Dual A-Arm Independent
Steering	Rack and Pinion
Braking System	4-Wheel Hydraulic Disc
Parking System	2-Wheel Gear Lock
Bed Dump	Electric Dump
Shocks	ELKA Stage 1
Seating	3 Occupant, Forward Facing Bench Seat
Auxiliary Power	USB Port with Gauge Connectivity
Display	7" (17.8 cm) Touchscreen Color Display with Bluetooth Connectivity
Hitch	2" (5.1 cm) Receiver Standard
Cargo Bed Space	35"x53"x13" (88.9cm x 134.6cm x 33cm)
Fuel Capacity	9 Gallons (34.1 L)
Warranty	1-year Bumper to Bumper
<b>Drive System</b>	
Displacement	997cc EFI Liquid Cooled
Bore x Stroke	92mm x 75mm
Compression Ratio	10.2:1
Carburetor	Electronic Fuel-Injected Throttle Body
Final Drive	Shaft Driven
Automatic CVT	Low/High/Neutral/Reverse/Park
Drive System	2WD, Electronic 4WD Selection
Cooling	Liquid
Starting	Electric Start
MAX Horsepower	83Hp (61.9 kW)
Fuel Type	87 Octane Gasoline (10% Ethanol Max) 91+ Recommended
Engine Oil Type	Intimidator SYN 5W-40
Speed	Up to 65 MPH (104.6 KPH)
<b>Measurements</b>	
Curb Weight	1,920 lb. (870.9 kg)
Length	122" (309.9 cm)
Width	64" (162.6 cm)
Height	82.5" (209.6 cm)
Frame Clearance	14" (35.6 cm)
Suspension Travel	10" (25.4 cm)
Cargo Bed Capacity	1,000 lb. (453.6 kg)
Vehicle Payload	1,450 lb. (657.7 kg)
GVWR	3,300 lb. (1,496.9 kg)
Towing Capacity	2,500 lb. (1,134 kg)
<b>Safety</b>	
Protection	1.75" (4.5 cm) Diameter Tubing Five Piece ROPS
Front Protection	1.75" (4.5 cm) Diameter Tubing Bumper/Brush Guard
Occupant Restraint System	Rotomolded Doors
Passenger Restraints	3 Point DOT Approved Restraint Belts
Shift Indicator	5 Position Gear Indicator Display
Headlights	LED – Automotive Style High and Low Beam
Brake/Tail Light	Standard

## GC1K Crew Stage 3

<b>Core Components</b>	
Frame	Powder-Coated Fusion-Bonded Solid Steel Bridge Frame
Body	Automotive Quality Acrylic Plastic
Front Tires	28x10.5x14 – 8 ply Radial
Rear Tires	28x10.5x14 – 8 ply Radial
Wheels	14" (38.1 cm) Wheels
Suspension	Dual A-Arm Independent
Steering	Rack and Pinion
Braking System	4-Wheel Hydraulic Disc
Parking System	2-Wheel Gear Lock
Bed Dump	Electric Dump
Shocks	ELKA Stage 1
Seating	6 Occupant, Forward Facing Bench Seat
Auxiliary Power	USB Port with Gauge Connectivity
Display	7" (17.8 cm) Touchscreen Color Display with Bluetooth Connectivity
Hitch	2" (5.1 cm) Receiver Standard
Cargo Bed Space	35"x53"x13" (88.9cm x 134.6cm x 33cm)
Fuel Capacity	9 Gallons (34.1 L)
Warranty	1-year Bumper to Bumper
<b>Drive System</b>	
Displacement	997cc EFI Liquid Cooled
Bore x Stroke	92mm x 75mm
Compression Ratio	10.2:1
Carburetor	Electronic Fuel-Injected Throttle Body
Final Drive	Shaft Driven
Automatic CVT	Low/High/Neutral/Reverse/Park
Drive System	2WD, Electronic 4WD Selection
Cooling	Liquid
Starting	Electric Start
MAX Horsepower	83Hp (61.9 kW)
Fuel Type	87 Octane Gasoline (10% Ethanol Max) 91+ Recommended
Engine Oil Type	Intimidator SYN 5W-40
Speed	Up to 65 MPH (104.6 KPH)
<b>Measurements</b>	
Curb Weight	2,268 lb. (1,028.7 kg)
Length	157" (398.8 cm)
Width	64" (162.6 cm)
Height	82.5" (209.6 cm)
Frame Clearance	14" (35.6 cm)
Suspension Travel	10" (25.4 cm)
Cargo Bed Capacity	1,000 lb. (453.6 kg)
Vehicle Payload	1,450 lb. (657.7 kg)
GVWR	3,300 lb. (1,496.9 kg)
Towing Capacity	2,500 lb. (1,134 kg)
<b>Safety</b>	
Protection	1.75" (4.5 cm) Diameter Tubing Five Piece ROPS
Front Protection	1.75" (4.5 cm) Diameter Tubing Bumper/Brush Guard
Occupant Restraint System	Rotomolded Doors
Passenger Restraints	3 Point DOT Approved Restraint Belts
Shift Indicator	5 Position Gear Indicator Display
Headlights	LED – Automotive Style High and Low Beam
Brake/Tail Light	Standard

## GC1K Truck

<b>Core Components</b>	
Frame	Powder-Coated Fusion-Bonded Solid Steel Bridge Frame
Body	Automotive Quality Acrylic Plastic
Front Tires	28x10.5x14 – 8 ply Radial
Rear Tires	28x10.5x14 – 8 ply Radial
Wheels	14" (38.1 cm) Wheels
Suspension	Dual A-Arm Independent
Steering	EPS Assisted Rack and Pinion
Braking System	4-Wheel Hydraulic Disc
Parking System	2-Wheel Gear Lock with Assisted Park Brake
Bed Dump	Dual Actuator Electric Dump
Shocks	Heavy Duty Base Shocks
Seating	3 Occupant, Forward Facing Bench Seat
Auxiliary Power	12V Accessory Port
Display	4.3" (10.9 cm) Color Display
Hitch	2" (5.1 cm) Receiver Front and Rear
Cargo Bed Space	73.3"x63.5"x14.1" (186.2cm x 161.3cm x 35.8cm)
Fuel Capacity	9 Gallons (34.1 L)
Warranty	1-year Bumper to Bumper
<b>Drive System</b>	
Displacement	997cc EFI Liquid Cooled
Bore x Stroke	92mm x 75mm
Compression Ratio	10.2:1
Carburetor	Electronic Fuel-Injected Throttle Body
Final Drive	Shaft Driven
Automatic CVT	Low/High/Neutral/Reverse/Park
Drive System	2WD, Electronic 4WD Selection
Cooling	Liquid
Starting	Electric Start
MAX Horsepower	83Hp (61.9 kW)
Fuel Type	87 Octane Gasoline (10% Ethanol Max) 91+ Recommended
Engine Oil Type	Intimidator SYN 5W-40
Speed	Up to 65 MPH (104.6 KPH)
<b>Measurements</b>	
Curb Weight	2,300 lb. (1,043.3 kg)
Length	157" (398.8 cm)
Width	64" (162.6 cm)
Height	82" (209.6 cm)
Frame Clearance	14" (35.6 cm)
Suspension Travel	10" (25.4 cm)
Cargo Bed Capacity	1,000 lb. (453.6 kg)
Vehicle Payload	1,000 lb. (453.6 kg)
GVWR	3,300 lb. (1,496.9 kg)
Towing Capacity	2,500 lb. (1,134 kg)
<b>Safety</b>	
Protection	1.75" (4.5 cm) Diameter Tubing Five Piece ROPS
Front Protection	1.75" (4.5 cm) Diameter Tubing Bumper/Brush Guard
Occupant Restraint System	Rotomolded Doors
Passenger Restraints	3 Point DOT Approved Restraint Belts
Shift Indicator	5 Position Gear Indicator Display
Headlights	LED – Automotive Style High and Low Beam
Brake/Tail Light	Standard

# Warranties

---

## Limited Warranty

### **Limited 1-Year Engine Warranty**

Intimidator, Inc. warrants to the original retail consumer that each new Intimidator Motors Gasoline engine sold by Intimidator, Inc., will be free from manufacturing defects in materials or workmanship in normal service for a period of one (1) year from the date of purchase provided it is operated and maintained in accordance with Intimidator, Inc.'s instructions and manuals. Please consult the Intimidator Owner's Manual for instructions and exclusions to this manufacturer's warranty.

### **1-Year Limited Drivetrain Warranty**

Intimidator, Inc. will, at its option, repair or replace, without charge, the drivetrain including gearbox, Constant Velocity Transmission (CVT) clutches excluding belt, transaxles excluding CV Joints, driveshafts and their subcomponents and differentials if found to be defective in material and/or workmanship within one (1) year after date of sale to the original retail purchaser of a new Intimidator 4x4 UTV model. This limited warranty is non-transferrable to a 2<sup>nd</sup> party and will be subject to certain limitations.

### **1-Year Limited Bumper-To-Bumper Warranty**

Intimidator, Inc. will, at its option, repair or replace, without charge, any part covered by the warranty which is found to be defective in material and/or workmanship within one (1) year after date of sale to the original retail purchaser of a new Intimidator, Inc. gasoline model. This limited warranty is non-transferable to a 2<sup>nd</sup> party and will be subject to certain limitations.

### **Replacement Parts**

Intimidator, Inc. dealers will repair or replace, at Intimidator, Inc.'s option, any defective part during the one (1) year warranty period. The parts to be warranted must be defective in material and/or workmanship. All replacement parts must be obtained from Intimidator, Inc. in order to comply with this manufacturer's warranty.

## Battery Warranty

The batteries used to power the Intimidator, Inc. will carry a 6-month free replacement warranty. These warranty claims will be handled by the battery manufacturer, Interstate Battery. Intimidator, Inc. does not assume any warranty obligation, liability, or modification for this item.

## Emissions Warranty

### **Emission System Warranty Statement (UTV)**

#### Distributor's Limited Warranties Emission Control Systems

Intimidator must warrant the emission control system on your 2018 and subsequent model year UTV for the period of time listed on the following page, provided there has been no abuse, neglect, or improper maintenance of your UTV.

Your emission control system may include parts such as the carburetor or fuel injection system, the ignition system, and engine computer. Also included may be hoses, belts, connectors, and other emission-related assemblies. Where a warranted condition exists, Intimidator will repair your UTV at no cost to you, including diagnosis, parts, and labor.

Intimidator UTVs comply with U.S. EPA emissions regulations. Intimidator provides the same warranty coverage to all motorcycle owners, regardless of where the UTV is registered.

### **Your Warranty Rights and Obligations**

In the United States, new UTVs must be designed, built, and equipped to meet stringent federal anti-smog standards. Intimidator must warrant the emissions control system on your UTV for the periods of time listed below, provided there has been no abuse, neglect or improper maintenance of your UTV. Your emissions control system may include parts such as the sensors, the ignition and the engine computer. Also included may be hoses, connectors, and other emissions-related assemblies. Where a warrantable condition exist, Intimidator will repair your UTV at no cost to you, including diagnosis, parts, and labor.

### **Manufacturer's Warranty Coverage**

If any emissions-related part on your UTV is defective, the part will be repaired or replaced by Intimidator. This is your emissions control system Defects Warranty.

### **Owner's Warranty Responsibilities**

As the UTV owner, you are responsible for the performance of the required maintenance listed in your Owner's Manual. Intimidator, Inc. recommends that

you retain all receipts covering maintenance on your UTV, but Intimidator cannot deny warranty solely for the lack of receipts or for your failure to ensure the performance of all scheduled maintenance. You are responsible for presenting your UTV to an Intimidator dealer as soon as a problem exists. The warranty repairs should be completed in a reasonable amount of time, not to exceed thirty (30) days.

### **Emission System Warranty Statement (UTV)**

As the UTV owner, you should also be aware that Intimidator may deny you warranty coverage if your UTV or a part has failed due to abuse, neglect, improper maintenance or unapproved modifications. If you have any questions regarding your warranty rights and responsibilities or if an authorized Intimidator dealer cannot repair your UTV or honor your claim within a reasonable period of time, contact Intimidator at: (866) 622-3269 for assistance. If you are not satisfied with the way in which a warranty claim is resolved by Intimidator, you may write directly to:

Director of Field Operations/Support Division (EI4-397F)  
Environmental Protection Agency  
Washington, D.C. 20460

### **Emissions Warranty Coverage**

Intimidator warrants to the owner of any 2016 and subsequent model year UTV that the unit is designed, built, and equipped to conform at the time of sale with all applicable emission standards, and is free from defects in materials and workmanship which would cause it to fail to conform with applicable requirements during the specified time and mileage limits.

This warranty begins on the date the UTV is delivered to the first purchaser other than an authorized Intimidator dealer, or the date it is first used as a demonstrator, lease, or company UTV, whichever comes first and continues for the time and mileage listed below:

Time: 30 Months; or

Mileage: 3,100 Miles (5,000 kilometers) – Whichever comes first. These warranties are given only to the owner of a 2016 and subsequent model year UTV distributed by Intimidator.

## **Emission System Warranty Statement (UTV)**

To qualify for coverage under the defects warranty you should operate and maintain your UTV according to the requirements of the Warranty Booklet, and the Maintenance Schedule in the Owner's Manual. This schedule is designed to keep your UTV emission control systems functioning properly by maintaining your UTV in peak operating condition. Intimidator will not deny a warranty claim solely because of lack of maintenance records. However, failures caused by abuse or lack of required maintenance will not be covered by this warranty.

Intimidator recommends that only parts supplied by Intimidator or equivalent parts be used to repair your UTV. Maintenance, replacement, or repair of emission control devices and systems may be done by an UTV repair establishment or individual. Intimidator will only pay for warranty repairs performed at an authorized Intimidator UTV repair facility (except in an emergency situation). An emergency situation exists when an Intimidator dealership is not reasonably available, a warranted part is not available within thirty (30) days, or when an authorized Intimidator facility is unable to complete a repair within thirty (30) days. In an emergency situation, the repair of emission control devices or system may be done by any UTV repair establishment or individual, or by the owner using any replacement part. Intimidator will reimburse you for those emergency repairs, including diagnosis, covered by the Emissions Warranties. Parts reimbursement is at the manufacturers' suggested retail price, and labor reimbursement is at a geographically-appropriate hourly labor rate for Intimidator recommended time allowance. For reimbursement, present the replaced parts and a copy of the paid receipt to Intimidator.

The use of replacement parts not equivalent to the original parts may impair the effectiveness of your UTV emissions control systems. If such a replacement part is used in the maintenance or repair of your UTV, and an authorized Intimidator dealer determines it is defective or caused a failure of a warranted part, your claim for repair to bring your UTV into compliance with applicable standards may be denied. If the part in question is not related to the reason you UTV fails to meet the standards, your claim will not be denied.

# Service Record

Number	Date	Hour Meter Reading	Dealer Stamp
1			
2			
3			
4			
5			
6			
7			
8			

# Intimidator, Inc. Utility Vehicle Owner's Registration and Training Certificate

(Keep original copy on file at your dealership)

<b>VIN/PIN</b>	
<b>Model</b>	
<b>Date of Purchase</b>	
<b>Dealer</b>	

## Purchaser

<b>Last Name</b>	
<b>First Name</b>	
<b>Address</b>	
<b>City</b>	
<b>State</b>	
<b>Postal Code</b>	
<b>Day Phone</b>	
<b>Evening Phone</b>	

# Pre-Ride Checklist

---

Complete this checklist before every operation of the Intimidator to ensure a safe and enjoyable ride.

**Tires and Wheels**

- Check condition for cuts or gouges
- Check for adequate tread
- Check air pressure and ensure that it is even in all tires
- Check wheel lugs for tightness

**Controls**

- Adjust steering wheel to ideal position
- Confirm that brake and throttle pedals operate smoothly
- Ensure proper brake and parking brake operation
- Ensure that the gear selector operates properly
- Inspect safety belts for wear or damage

**Lights**

- Make sure lights (high and low beams) operate properly as well as brake lights

**Oil and Fluids**

- Oil – check level and condition
- Fuel – check level
- Coolant – check level and condition
- Leaks – inspect inside and underneath the machine for evidence of fluid leaks

**Chassis and Accessories**

- Ensure all shocks, fasteners, and undercarriage are free from damage and securely fastened
- Check ROPS for secure attachment and damage
- Ensure nets and doors are in good condition and close/attach properly
- Inspect all accessories for secure attachment and damage